

## Digital PA and Emergency Sound

# 2

<b>Praesideo System</b>	<b>86</b>
<b>Praesideo Peripherals</b>	<b>133</b>
<b>Praesideo Accessories</b>	<b>148</b>
<b>Praesideo - Configuration Examples</b>	<b>151</b>

## Praesideo - Digital Public Address and Emergency Sound System



Praesideo is a fully digital public address system that meets all the requirements placed by professional users on a public address/emergency sound system. It brings highly innovative and advanced digital technology to the public address market. The processing and communication of both audio signals and control data entirely in the digital domain makes the system superior to other currently available public address and emergency sound systems. Digital signal processing allows significant improvements in audio quality to be achieved. The Praesideo system is configured from a PC, making installation and configuration very simple and user-friendly.

All audio processing is digital. Communication between the units is via plastic fiber or glass fiber cabling, depending on the distance between the units. Because the system uses the daisy chain principle, cabling and installation are very quick, simple and easy.

### User-friendly Software Control

The system has user-friendly software to configure all system functions. The software is web-based technology, and provides authorized users full freedom of configuration: any time and from anywhere in the network. A simple and well-organized user interface provides an intuitive environment for configuring the system. The software has plausibility checks, and informs the user of any parameters, which have not been set, before exiting from any stage of the configuration process.

### Network Approach

The system architecture is based on the daisy chaining of units. Equipment can be placed anywhere a network connection is available. Customers can expand their systems easily without adding additional electronics to the network controller unit. Thanks to this network architecture, a small initial system can be expanded later by simply adding the required new units to the existing network. The same is true for modifications to the PA system that become necessary later, due to reorganizations, structural changes, etc.

The system can be configured for redundant cabling using a ring cabling structure.



**Distributed Control**

The system design distributes the control of various system functions, as well as processing, throughout the system. The external interfaces, inputs and outputs, can be located anywhere in the network. All units can process audio input and output signals. This allows the network controller to concentrate on other activities such as the routing of announcements, taking actions on control inputs, etc. As a result, the response times are much shorter than for those of systems with centralized processing of all signals. The system scales gracefully, because each new unit increases the overall digital signal processing power of the system.

**Combination of Functions**

The Praesideo range of equipment has multiple functions combined in a single unit. This feature drastically reduces the number of different types of equipment used in the system. For example, functions such as audio processing, audio delay, amplifier monitoring (including spare switching), and speaker line monitoring are provided by the power amplifier unit itself. This makes the overall system highly cost-effective. The flexible architecture of the Praesideo range of equipment allows the customer to locate any type of equipment anywhere in the building. The configuration software lets an administrator/installer configure any units in the system from any PC with a network connection to the network controller. No local configuring at the equipment end is required, drastically reducing the installation and commissioning time, as well as any changes, which become necessary after commissioning.

**EN 60849 and EN 54-16 Certified**

The Praesideo range of equipment complies with the various emergency standards, which are applicable all over the world. The network controller can supervise all units in the system, from the microphone capsule of the call station to the loudspeaker line and loudspeakers. A built-in memory stores the last 200 fault messages. All faults are reported back to the network controller. The system also fulfills the requirements for emergency call stations. The open system architecture has the flexibility to provide large numbers of in and outputs, making even the most demanding emergency applications possible.

**External Interfaces**

Administrators and installers can configure the control inputs to initiate the desired actions in the system. The ability to route any input from one system unit to any other unit makes it possible to use the Praesideo range of products for a wide range of public address and emergency sound system applications.

**Reduced Installation Costs**

The Praesideo architecture uses the daisy chain principle for both data and audio signals. This makes the system wiring very cost-effective, using two fiber cores for data and audio communication, and a copper wire pair to supply power from the network controller to the units.

**High System Flexibility**

The Praesideo system is an extremely versatile system. It gives system designers a high degree of flexibility in the number of zones, call stations, audio and control in and outputs, etc., that they can use. The flexibility of unit distribution is also greater than legacy systems, and it is usually easier to place elements closer to where they are needed.

**System Overview****Network Controller**

The network controller is the heart of the system, and stores all configuration information. It provides the Ethernet interface for connection to the PC to enable system configuration, as well as diagnostic and logging functions. The network controller stores the digital audio messages for (scheduled) announcements on a built-in flash card. The controller monitors all the system components and reports any changes in status. The unit provides four audio inputs and four outputs, as well as eight control inputs and five control outputs. The control inputs can trigger actions in the system. Administrators and installers can define the control input characteristics in the configuration software. Control inputs can be programmed for momentary or toggle operation, act on make or break, supervision, etc. They can be used to initiate actions, and can be linked to external equipment. The network controller stores and shows the last 200 fault messages. The availability of the digital audio messages, the alarm tones, and the control inputs are continuously supervised. An internally generated pilot tone can be provided on the audio outputs for monitoring purposes.

**Power Amplifiers**

There are four types of power amplifier units in the Praesideo product range. These differ in the number of amplifier channels per frame: one, two, four, or eight. The overall power rating is 500 watts for all of the amplifiers.

The power amplifiers can be selected for 100 V, 70 V and 50 V output tapping. The fiber optic network cable provides audio input. The amplifiers are equipped with amplifier supervision and spare amplifier changeover relays. They have short-to-ground and short-circuit detection functions, and can generate their own pilot tone for supervision purposes.

Loudspeaker and/or line supervision control boards can be added to an amplifier. The control board communicates with supervision boards at the end of the line and/or in individual loudspeakers. Their status is communicated over the loudspeaker line itself without interfering with the audio signal.

The power amplifiers are equipped with audio processing facilities for each amplifier channel. They support configurable delay, three parametric equalizer sections and two shelving equalizers per channel. An ambient microphone connection enables automatic output level adjustment for maximum intelligibility. The power amplifier has a supervised connection for a 48 VDC backup power supply.

#### Multi Channel Interface and Basic Amplifiers

The basic amplifiers are cost effective alternatives to the regular Praesideo power amplifiers, for situations where no built-in digital signal processing functions, such as equalizers, delay and AVC are required. They do not have a Praesideo network connection. Instead, these amplifiers are connected to the Praesideo network via the multi channel interface.



The basic amplifiers are high-efficiency, class-D power amplifiers for public address and emergency sound systems. The multi channel interface provides audio signals to all basic amplifier channels and has full control. The basic amplifier is fully supervised, and fault events are reported via the multi channel interface to the Praesideo network controller. The amplifiers have connections for separate group A and group B loudspeakers in a zone and can be configured for class-A loudspeaker loop wiring.

The multi channel interface provides 16 configurable output channels (14 main outputs and 2 spare outputs), 32 control inputs and 16 control outputs. With its built-in supervision controller, it can also take care of loudspeaker and loudspeaker line supervision for all connected basic amplifier outputs.

#### Call Station Basic

The call station basic has a direct network interface, one press-to-talk-key, a monitoring speaker and a headphone socket. The volume control on the front of the unit adjusts the loudspeaker or headphone volume. Up to 16 call station keypads can be connected to the unit. LEDs on the unit indicate the status of the system, call station, and call.



#### Call Station Keypad

The call station keypad has eight selection keys and status indicators. This unit connects to a basic call station through a local interface. Each selection key has one bi-color LED, which shows the status of the selection.

#### Call Station Numeric Keypad

The numeric keypad provides a telephone-like user interface for numeric zone and zone group selection. It connects to a basic or remote call station and has a LCD to show selections and their status. Also a user access control function can be configured.

#### Call Station Kit

The call station kit has the same functions as the basic call station, and is intended for the construction of custom-made units. The kit is supplied without a housing for easy installation in panels, walls or custom made housings. It has a power supply input for both the call station itself and the call station keypads. The external power supply can be monitored by connecting its fault control output to the control input of the call station kit.

#### Call Station Keypad Kit

The kit is a call station keypad without housing, but with the same functionality. The kit facilitates the construction of custom applications, where special placement, custom switches, and/or custom indicators are desired.

**Call Station Remote**

In many applications, call stations must be located relatively far away from the rest of the system. For such cases, the Praesideo system provides the remote call station as a cost-effective alternative. It has the same functionality as the basic call station, but does not connect to the Praesideo network directly. Instead, it connects to the call station interface via a CAT 5 cable with a maximum length of 1000 meters. Thus, the distance from the remote call station to the network is not part of the overall network length. Often an existing CAT 5 cable can be used, further reducing costs. Up to 16 call station keypads or call station keypad kits can be connected, including numeric keypad.

**Call Station Remote Kit**

The remote kit is a version of the remote call station with the same functionality, but without the housing for easy installation in custom-applications.

**Call Stacker**

The call stacker is a unit that records calls that cannot be sent to all required zones because some are occupied by a higher priority call. Recorded calls are automatically repeated to these zones when they become available. The call stacker can also be used as time-shifter to avoid acoustic feedback from a loudspeaker to the active microphone. The call is recorded and broadcast after the recording has finished. The call can be pre-monitored before broadcast with the option to cancel the call.

**Call Station Interface**

The call station interface is a unit that interfaces between a remote call station and the Praesideo network. Because a remote call station uses CAT 5 cable for interconnection and does not have Praesideo network connections, a call station interface is needed. The call station interface also provides a local power input as well as control inputs, and delivers power to the remote call station. The call station interface interfaces to the remote call station via a bidirectional digital interface. Because not all 28 Praesideo audio channels, but only the required microphone and monitor audio channels are transported on this interface, the bit-rate is much lower. The lower bit rate allows the interconnection cable to be much longer than the typical Praesideo network connection between units.

**Audio Expander**

The audio expander can provide additional audio inputs and outputs to the system. The unit has four transformer isolated audio inputs and four transformer isolated audio outputs, as well as eight control inputs and five control outputs. The audio inputs can be configured for background music, microphone or line inputs. The control inputs can be configured to initiate actions.

**CobraNet Interface**

The CobraNet interface can insert up to four audio channels from CobraNet into the Praesideo system and up to four audio channels from Praesideo into a CobraNet network. CobraNet, developed by Peak Audio (a division of Cirrus Logic, Inc.), is a network protocol for real-time uncompressed digital audio distribution over industry standard 100Base-T Ethernet networks. Digital audio data is directly converted between Praesideo and CobraNet with no audio processing other than sample rate conversion.

Control inputs and outputs provide external interfacing. The CobraNet interface gets its power from the Praesideo network and does not need a mains or battery connection. CobraNet interfaces are often used to interconnect two or more Praesideo subsystems via Ethernet. The audio channels are transported via CobraNet and the Praesideo control data via the Praesideo Open Interface.

**IP Audio Interface**

The IP audio interface is a universal, IP-based audio device supporting VoIP and audio over IP applications. It is an ideal solution for bridging audio and contact closures over long distance LAN and WAN networks. It extends and interfaces to Praesideo and non-network based traditional public address systems without the need for a PC during operation.

**Network Splitter**

The network splitter allows the main network line to be split into branches. The branch lines are still supervised, but do not have the redundant cabling of the main network line. The network splitter has an option to connect a 48 VDC supply that can supply additional power if required. The network splitter can also function as a repeater to extend the cable another 50 meters with plastic fiber.

**Fiber Interfaces**

Most of the Praesideo system units have plastic fiber optic interfaces. Plastic fiber is used to interconnect nodes which are less than 50 meters apart. For distances of more than 50 meters, glass fiber optic cable is used. A fiber interface converts from plastic to glass fiber, and vice versa. The fiber interface has a power supply input to provide power to remote network sections, and two control inputs. The control inputs can pass on supervision information about the power supply connected to the fiber interface.

90 | Digital PA and Emergency Sound | Praesideo System

Different models exist for single-mode and multi-mode glass fiber.

2

**Certifications and Approvals**

<b>Region</b>	<b>Certification</b>
Europe	CE KEMA TUEV-SUED GL
Poland	CNBOP

## PRS-NCO-B Network Controller



### Features

- ▶ **Public address and emergency sound system control unit**
- ▶ **Fully digital with four audio inputs and four audio outputs**
- ▶ **Control and routing of 28 audio channels**
- ▶ **Eight supervised control inputs and five control outputs**
- ▶ **Ethernet interface for configuration, control, diagnostics, and logging**
- ▶ **Digital storage for prerecorded messages**
- ▶ **Stores the last 200 fault events**

The network control unit is the heart of the Praesideo system. The unit routes up to 28 simultaneous audio channels, delivers power to the system, reports faults, and controls the system. Audio inputs can be announcements from call stations, background music, or local audio. The network control unit can be configured for the most complex public address systems. The configuration can be done comfortably and efficiently via a PC. The PC is only needed for configuration. The controller can operate independently of the PC. However, the controller can use a PC to display information on the system status using the software, supplied with the unit. The unit can be freestanding on a tabletop or mounted in a 19" rack.

### Functions

#### Connectivity

The network controller has four analog audio inputs. Of these, two are selectable between microphone and line. The other two inputs are fixed as line inputs. The microphone/line inputs can be used as call inputs, if they are programmed conditionally to any of the eight control inputs, which are freely programmable for system actions, with freely programmable priorities.

The controller has four analog audio line outputs each with a selectable 20 kHz monitoring signal. Three control outputs are programmable for faults or calls, and two others are used to connect visual and audible fault indicators.

#### Operation and performance

The network controller is completely configurable from a PC using the supplied software, which can also provide the current status of the running system, as well as comfortable and efficient configuration. The controller can also run without a connected PC, once it has been configured. The front panel has a 2 x 16-character LCD display and a rotary control to navigate through the menu and select the menu items. Address, version, fault events, and monitor enquiries can be done using the display and control knob. The network controller can control up to 60 nodes. Nodes include equipment such as power amplifiers, audio expander units, call stations, call station kits, etc.

To meet the requirements for emergency sound systems, automatic messaging is included in the network controller. The controller has a built-in, replaceable compact flash memory card, to match the storage requirements for audio messages. Four messages can be played simultaneously. Message storage and of the messages themselves are monitored. Audio messages (as a set of wav files) can be downloaded from a computer via the Ethernet link. The controller also stores wide range of attention tones, test tones, and alarm tones, all accessible by any call stations or control inputs for announcement or alarm broadcast. An internal real time clock lets the network controller automatically do things, such as playing scheduled announcements or changing the volume of background music during evening hours. It has extensive audio processing possibilities for the audio inputs and the audio outputs. Parametric equalization, limiter and gain can be easily adjusted using the configuration software. There is a headset jack for monitoring the audio channels.

#### Security

The network controller supports redundant network cabling. It can be wired as a branched network or redundant loop. The system can handle 256 priorities, for calls to hundreds of zones, satisfying even the most complex public address and emergency requirements.

The controller monitors the status of all the equipment in the system, reports status changes, and stores the last 200 fault messages in the system. This monitoring extends from the capsule of a call station microphone to the end of a loudspeaker line. The external cables connected to the control inputs are monitored for short and open circuit. An internally generated pilot tone is available for monitoring the audio outputs. The controller operates both on mains power and on a 48 V battery power supply for emergency back up, with automatic switchover. It can supervise both of the power supplies.

**Controls and indicators**

**Front**

- 2 x 16-character LCD display
- Rotary/push button

**Back**

- Mains switch
- Voltage selector

**Interconnections**

**Front**

- Headphone output

**Back**

- Mains input
- Battery backup input
- Eight control inputs
- Two analog audio mic/line inputs
- Two analog line audio inputs
- Five control outputs (two dedicated fault)
- Four analog audio line outputs
- Ethernet
- RS232
- Two system network connections

**Certifications and Approvals**

Safety	acc. to IEC 60065 / EN 60065
Immunity	acc. to EN 55103-2 / EN 50130-4 / EN 50121-4
Emissions	acc. to EN 55103-1 / FCC-47 part 15B
Emergency	acc. to EN 60849 / EN 54-16 / ISO 7240-16
Maritime	acc. to IEC 60945

**Installation/Configuration Notes**

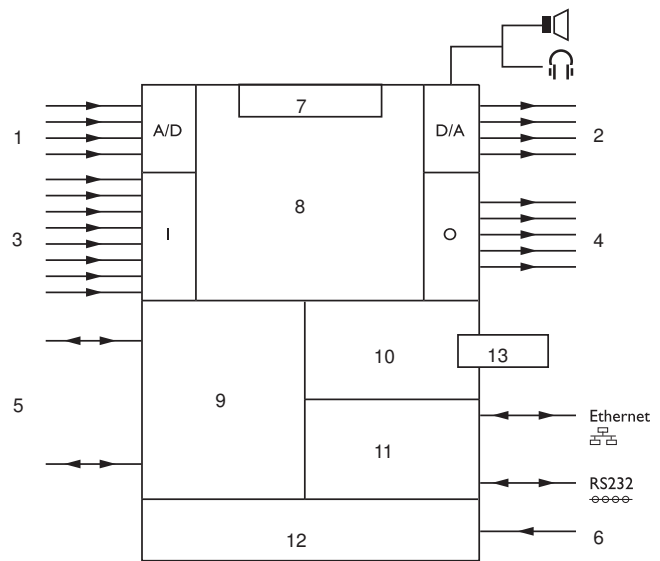

- 1 Audio inputs
- 2 Audio outputs
- 3 Control inputs
- 4 Control outputs
- 5 Plastic optical fiber network
- 6 Mains
- 7 Display and control
- 8 Network processor and DSP
- 9 Network redundancy switching
- 10 Message manager
- 11 Micro processor
- 12 Power supply
- 13 Compact flash (CF) memory card



Rear view

**Parts Included**

Quantity	Component
1	PRS-NCO-B Network Controller
1	Power cord
1	Set of mounting brackets for 19" rack
1	Set of feet
1	Set of connectors
1	PRS-SW Configuration, Diagnostic and Logging Software

**Technical Specifications****Electrical****Mains power supply**

Voltage	115/230 VAC ±10%, 50/60 Hz
Power consumption	14 W with no load 150 W with maximum load

**Battery power supply**

Voltage	48 VDC -10% to +20%
---------	---------------------

**Performance**

Frequency response	20 Hz to 20 kHz (-3 dB)
--------------------	-------------------------

**Line inputs** 2 x

Connectors	3-pin XLR and stereo cinch (for each line)
S/N	>87 dBA at maximum level
CMRR	>40 dB
Input range	+6 dBV to +18 dBV (XLR) -6 dBV to +6 dBV (cinch)

**Control inputs** 8 x

Connectors	Removable screw terminals
Operation	Closing contact (with supervision)

**Control outputs** 5 x

Connectors	Removable screw terminals
------------	---------------------------

**Mic / line inputs** 2 x

Connector	3-pin XLR
Nominal Input Level	-57 dBV
S/N	>62 dBA with 25 dB headroom
CMRR	>55 dB at 100 Hz
Input Impedance	1360 ohm
Phantom supply	12 V ±1 V @ 15 mA
Input range	-7 dB to 8 dB ref nominal input level
<b>Line outputs</b>	4 x
Connectors	XLR and stereo cinch (for each line)
Output Impedance	<100 ohm
S/N	>89 dBA at maximum level
Crosstalk	<-85 dB
Signal range	-12 dBV to +18 dBV (XLR) -24 dBV to +6 dBV (cinch)
Distortion at 1 kHz	<0.05%

**Mechanical**

Dimensions (H x W x D)	
tabletop, with feet	92 x 440 x 400 mm (3.6 x 17.3 x 15.7 in)
in rack, with brackets	88 x 483 x 400 mm (3.5 x 19 x 15.7 in)
in front of brackets	40 mm (1.6 in)
behind brackets	360 mm (14.2 in)
Weight	7 kg (15.4 lb)
Mounting	Standalone; 19" rack
Color	Charcoal with silver

**Environmental**

Operating temperature	-5 to +55 °C (+23 °F to +131 °F)
Storage temperature	-40 to +70 °C (-40 °F to +158 °F)
Humidity	15% to 90%
Air pressure	600 to 1100 hPa

**Ordering Information**

<b>PRS-NCO-B Network Controller</b>	<b>PRS-NCO-B</b>
routes up to 28 simultaneous audio channels, delivers power to the system, reports faults, and controls the system	

**Software Options**

<b>PRS-SW Praesideo Software</b>	<b>PRS-SW</b>
Configuration software, Diagnostic & logging software, File transfer software.	

## PRS-SW Praesideo Software

2

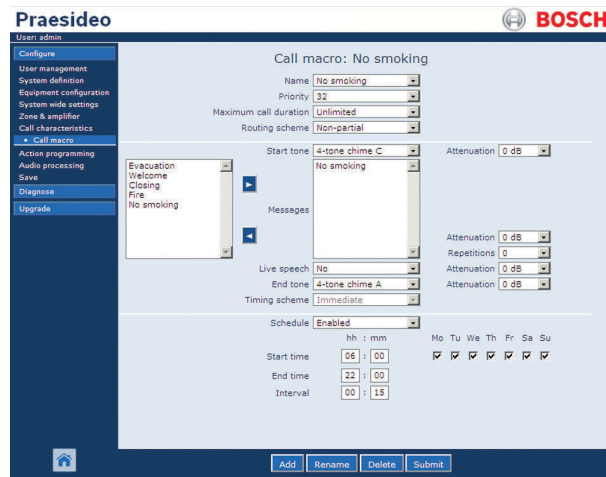

### Features

#### Configuration software

- ▶ **Web-based user interface**
- ▶ **Can be accessed using a PC with browser**
- ▶ **Different levels of access rights can be assigned**
- ▶ **All system and unit parameters can be configured**
- ▶ **Easy navigation**
- ▶ **Dynamic HTML pages**

#### Diagnostic and logging software

- ▶ **Logging of call events, fault events and general events**
- ▶ **On-line logging function**
- ▶ **View history**
- ▶ **Events can be sorted**
- ▶ **Password-protected**

#### File transfer software

- ▶ **PC application**
- ▶ **Supplied together with the network controller**
- ▶ **Creation of message sets**
- ▶ **Off-line configuration**

This software has three parts:

- Configuration software, which is installed in the network controller
- Diagnostic & logging software, which is installed in the network controller, and optionally on a logging PC
- File transfer software, which is to be installed on the configuration PC and supplied together with the network controller

### System Overview

#### Configuration software

The configuration software is required for every system. Once the configuration data entry has been completed and downloaded to the network controller, the system can operate without the configuration PC. The configuration software is required only during installation and to make changes to an existing system configuration. The configuration software design allows even first-time users to navigate easily through the configuration.

#### Diagnostic and logging software

The main function of the diagnostic & logging software is to monitor and record the status of all elements of the PA system. This software logs all events, such as calls and changes in the status of system components, and displays the current status of the system. It can provide real-time logging to a PC.

#### File transfer software

The file transfer software transfers both data and message files from the PC to the network controller.

### Functions

#### Configuration Software

The software supports three access levels: administrator, installer, and user. Each of the three levels carries different access rights.

Call macros allow users to configure various functions and/or actions that can be assigned to inputs such as control inputs and call station keys. The same call macro can be assigned to multiple inputs. A call macro defines: priority, start and end tones, an audio input, a message or sequence of messages, number of repetitions, scheduling with duration and interval, and more.

Zone grouping allows the user to define zones covering the same types of area. In the zone configuration, zone-related items such as amplifier channel outputs, audio outputs and control outputs can be assigned to defined zones.

A power amplifier can be linked to a spare power amplifier so that if there is a fault in the power amplifier it will automatically change over to the spare power amplifier. The ratio of main power amplifiers to spare power amplifiers is flexible, and can be configured to meet specific application requirements.

The software can configure all equipment inputs and outputs in the system. All audio inputs and outputs have audio processing facilities, including parametric equalization with high and low-pass filters for inputs and outputs, and gain and limiter adjustments for inputs only. The audio inputs can be set to microphone or line. Delays can be configured for each amplifier output individually. The level of the 20 kHz pilot tone will be adjusted automatically. Keys on call station keypads can be configured with various functions. A call station can be

defined as an emergency call station, with the ability to add zones or audio outputs during an announcement. Control inputs can be configured for a sequence of functions. Control inputs can be configured for monitoring lines connected to them for open-circuits and short-circuits. Zones can be configured for various, time-based volume settings. BGM sources can be assigned to music channels, which can be assigned to different zones/audio outputs.

#### **Diagnostic and Logging Software**

Modes of enquiry supported by the software include general events, call logging, and fault logging. This part of the software allows monitoring the fault status of all units, as well as any status changes in the system. Users can view the last 200 fault messages, which are stored in the network controller. Control inputs can be used for reporting the fault status of third-party equipment, which is not part of the Praesideo system, allowing users to view logged events of monitored external devices. The software also provides control of audible and visual fault indicators. Faults and alarm states can be acknowledged and reset, and the acknowledgement and reset actions are logged. Optionally, a PC-based logging server can store events from multiple systems in a database. This can be accessed remotely by a dedicated Praesideo log viewer program.

#### **File Transfer Software**

File transfer is protected by user IDs and passwords. The message set (a set with multiple wav files), which has to be stored in the network controller, can be assembled, stored on the PC and sent to the network controller. A configuration file, which has been created in off-line mode, can be transferred to the network controller. The configuration file can also be retrieved from the network controller.

---

#### **Certifications and Approvals**

Emergency                      acc. to EN 60849 / EN 54-16 / ISO 7240-16

---

#### **Ordering Information**

<b>PRS-SW Praesideo Software</b>	<b>PRS-SW</b>
Configuration software, Diagnostic & logging software, File transfer software.	

## PRS-SWCS PC Call Server and PRS-SWCSL PC Call Server NCO Client

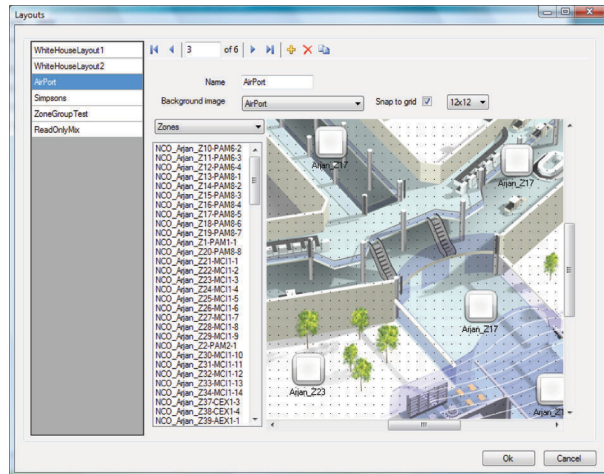

### Features

- ▶ Serves multiple Call Station Clients and/or Telephone Interface Clients
- ▶ Controls multiple Network Controllers in extended systems
- ▶ Includes a license for a single Network Controller
- ▶ Controls user access with selectable rights per user

The PRS-SWCS PC Call Server is a Windows service connected to one or more Praesideo network controllers via TCP/IP, using the Praesideo open interface. It is used in combination with one or more client applications, such as the PC Call Station Client and the PC Telephone Interface Client, handling all operational requests.

The PRS-SWCS PC Call Server is configured via an included PC Call Server Configuration Client, running on the same computer.

### Functions

#### Configuration and Control

The PRS-SWCS PC Call Server provides facilities for connected clients, such as identification, making of calls, BGM source and volume control, acknowledge and reset of emergency modes, time synchronization and license control. It operates on Windows XP, Vista and Windows 7 platforms.

Via the PRS-SWCS PC Call Server Configuration Client the connections of the connected network controllers can be monitored and set up. In case of multiple network controllers audio connections between network controllers can be configured to enable calls from one Praesideo network to other Praesideo networks.

Configuration data of each connected Praesideo subsystem can be retrieved from the network controllers and used for configuration of the PRS-SWCS PC Call Server. Multiple views of a system can be configured as background images with zone and zone group locations, independent for different users of clients. Also multiple predefined calls can be configured for different users which can be accessed via e.g. one or more PRS-CSC PC Call Station Clients. These predefined calls may contain information about priority, zones, tones, messages, live speech and zones. The zones can be part of different Praesideo systems, as long as all these systems are connected to the PRS-SWCS PC Call Server.

The PRS-SWCS PC Call Server allows control of BGM source and volume in the configured zones and gives feedback about the actual volume to the clients.

### License

The PRS-SWCS PC Call Server uses a USB dongle for identification of the system for all licenses purchased. The dongle is supplied with the PRS-SWCS PC Call Server. The PRS-SWCS PC Call Server already comes with a license for use with one network controller. Additional licenses for more network controllers, connected to the same PRS-SWCS PC Call Server are available as PRS-SWCSL PC Call Server NCO License.

Applications, such as the PRS-CSC PC Call Station Client, also require a license. Only one application license is required, independent of the number of clients (operator panels) that are connected.

### Parts Included

1	PRS-SWCS PC Call Server license (including license for one network controller).
1	USB dongle
1	PRS-SW Praesideo software CD

**Ordering Information**

<b>PRS-SWCS PC Call Server</b> Windows service connected to one or more Praesideo Network Controllers via TCP/IP	<b>PRS-SWCS</b>
<b>PRS-SWCSL PC Call Server NCO License</b> License for one additional Praesideo Network Controller.	<b>PRS-SWCSL</b>
<b>PRS-SWCSL-E PC Call Server NCO License E-code</b> License for one additional Praesideo Network Controller (EMEA region only).	<b>PRS-SWCSL-E</b>
<b>PRS-CSC PC Call Station Client</b> A client of the PC Call Server, to be used in combination with the PC Call Server.	<b>PRS-CSC</b>
<b>PRS-CSC-E PC Call Station Client E-code</b> A client of the PC Call Server, to be used in combination with the PC Call Server (EMEA region only).	<b>PRS-CSC-E</b>
<b>PRS-TIC PC Telephone Interface Client</b> A client of the PC Call Server, to be used in combination with the PC Call Server.	<b>PRS-TIC</b>
<b>PRS-TIC-E PC Telephone Interface Client E-code</b> A client of the PC Call Server, to be used in combination with the PC Call Server (EMEA region only).	<b>PRS-TIC-E</b>

## PRS-CSC PC Call Station Client

2



### Features

- ▶ **PC interface for operators with synoptic view of zone locations in tabbed windows**
- ▶ **Configurable access for different users**
- ▶ **Call and BGM control**
- ▶ **Support for multiple network controllers as one system**

The PRS-CSC PC Call Station Client is a client of the PRS-SWCS PC Call Server and must be used in combination with the PRS-SWCS PC Call Server. It operates with Windows XP or Vista and can be used on the same PC as the PRS-SWCS PC Call Server or on different PCs. An almost unlimited number of PRS-CSC PC Call Station Clients can be installed and used under the same license.

### Functions

#### User interface

The PRS-CSC PC Call Station Client provides a graphical user interface to the operator where the operator can select predefined calls, add or remove zones from that predefined call by clicking on zone icons in a graphical system layout, and then start, stop and/or abort this call. Multiple calls can be active simultaneously from the same client.

Zone icon appearance shows the status of each zone. The library of zone icons and background colors can be modified by the customer.

Also BGM source selection and volume can be selected and controlled per zone. The actual source and volume setting is shown in the zone icon for each zone.

### Configuration

In the configuration of the PRS-SWCS PC Call Server access rights per user are set, e.g. the right to start certain predefined calls or to access certain zones or overviews.

A logo of the company or site where the PRS-CSC PC Call Station Client is located can be added to the user interface. Also different user languages can be selected from a growing list of supported languages.

### Parts Included

- 1 PRS-CSC PC Call Station Client license

### Ordering Information

<b>PRS-CSC PC Call Station Client</b>	<b>PRS-CSC</b>
A client of the PC Call Server, to be used in combination with the PC Call Server.	
<b>PRS-CSC-E PC Call Station Client E-code</b>	<b>PRS-CSC-E</b>
A client of the PC Call Server, to be used in combination with the PC Call Server (EMEA region only).	
<b>PRS-SWCS PC Call Server</b>	<b>PRS-SWCS</b>
Windows service connected to one or more Praesideo Network Controllers via TCP/IP	
<b>PRS-SWCSL PC Call Server NCO License</b>	<b>PRS-SWCSL</b>
License for one additional Praesideo Network Controller.	
<b>PRS-SWCSL-E PC Call Server NCO License E-code</b>	<b>PRS-SWCSL-E</b>
License for one additional Praesideo Network Controller (EMEA region only).	

## PRS-TIC PC Telephone Interface Client

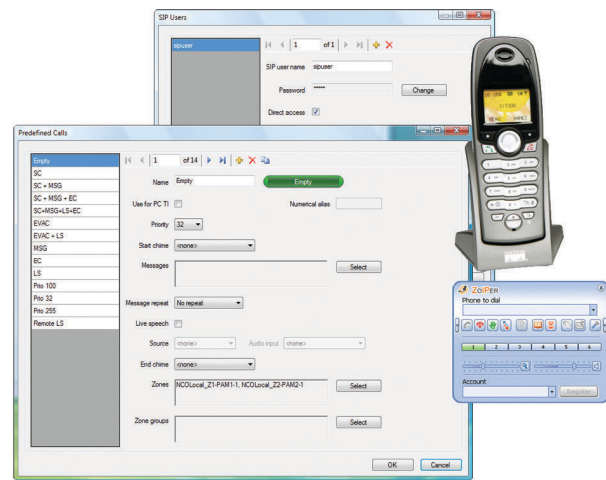

### Features

- ▶ **PC interface software for making calls via telephone into a Praesideo system**
- ▶ **Direct support of VoIP telephones and support of POTS telephones via external interface (not included)**
- ▶ **Configurable access options per user**
- ▶ **Calls are recorded before playback**
- ▶ **Support for multiple network controllers as one system**

The PC Telephone Interface Client is a client of the PC Call Server and must be used in combination with the PC Call Server. It operates with Microsoft Windows XP or Vista. The PC Telephone Interface Client must be used on the same PC as the PC Call Server.

### Functions

#### VoIP interface

The PC Telephone Interface Client acts as an interface between incoming VoIP calls and the Praesideo PC Call Server to make live calls into a Praesideo system, using a telephone, hardphones as well as softphones. A traditional POTS telephone or PBX connection can be converted to VoIP via a Call Routing Gateway (the Cisco Linksys SPA3102 is recommended, but not included with the PRS-TIC).

#### Voice response menu

A voice response menu is used for feedback to the caller about selections that can be made. Selections include caller identification with access control and selection of a predefined call.

A predefined call includes priority information and may include start and end chimes, prerecorded messages, a set of zones and/or zone groups and the possibility to add live speech (an announcement) to the call.

Via the voice response menu the caller can add zones or zone groups to the set already defined in the predefined call and the caller may be prompted for the live announcement. The announcement of the caller is recorded on the PC and will be played back after completion of the call.

The caller can make subsequent calls via the telephone without waiting for the broadcast of the previous call to be finished. The last call, including the live announcement, can simply be repeated without having to enter all data and the live announcement again.

The content of the voice response menu can be changed by replacing the sound files (in gsm-format). This way the voice response menu can be adapted to different languages or be made more customer specific. Sound processing software and a file format converter to gsm-format are included.

#### PC Call server

Because the telephone calls are processed by the Praesideo PC Call Server, big systems with multiple network controllers can be addressed. Configuration of the PC Telephone Client is also part of the PC Call Server. Here the access rights per user/caller are set, e.g. the right to start certain predefined calls or to access certain zones.

Direct access to make telephone calls into Praesideo can be configured for callers that call-in from a VoIP interface. Identification is done via user name and password of the SIP account, so no additional caller identification is required via the voice response menu and calls can be made quicker.

### Parts Included

Quantity	Component
1	PC Telephone Interface Client license

**Ordering Information****PRS-TIC PC Telephone Interface Client      PRS-TIC**

A client of the PC Call Server, to be used in combination with the PC Call Server.

**PRS-TIC-E PC Telephone Interface Client      PRS-TIC-E****E-code**

A client of the PC Call Server, to be used in combination with the PC Call Server (EMEA region only).

**PRS-SWCS PC Call Server      PRS-SWCS**

Windows service connected to one or more Praesideo Network Controllers via TCP/IP

**PRS-SWCSL PC Call Server NCO License      PRS-SWCSL**

License for one additional Praesideo Network Controller.

**PRS-SWCSL-E PC Call Server NCO License      PRS-SWCSL-E****E-code**

License for one additional Praesideo Network Controller (EMEA region only).

## PRS-xPxxx and LBB 4428/00 Power Amplifiers



### Features

- ▶ **1, 2, 4, or 8 audio outputs (selection from 100 / 70 / 50 V outputs)**
- ▶ **Audio processing and delay for each amplifier channel**
- ▶ **Amplifier supervision and spare amplifier switching**
- ▶ **Loudspeaker line and loudspeaker supervision (LBB 4428/00 only line supervision)**
- ▶ **Eight control inputs and 1, 2, 4 or 8 control outputs**
- ▶ **Supervision of line attached to control inputs**
- ▶ **Automatic volume control**
- ▶ **Two audio inputs (four audio inputs for LBB 4428/00)**
- ▶ **Redundant network connection**

There are four types of Power Amplifier units in the Praesideo product range. These differ in the number of amplifier channels per frame: one, two, four, or eight. The overall power rating is 500 watts for all of the amplifiers.

The Power Amplifiers can be set to 100 V, 70 V and 50 V output tapplings. They have short-to-ground and short-circuit detection functions, and can generate their own pilot tone for supervision purposes.

### Functions

The Power Amplifiers receive input signals over the network. They also have two auxiliary audio inputs (four for LBB 4428/00) for local audio. Their eight control inputs are freely programmable for system actions, and priorities can be assigned to these inputs. Each control input has the ability to monitor the attached line for open and short-circuits. Control outputs are freely programmable for faults and call related actions.

The 2 x 16-character display and the rotary control enable local status enquiries. The display shows the VU-meter reading, when the audio monitoring mode is active. Audio can be monitored by headphone.

The units are self-monitoring and continually report their status to the network controller. They support both single branch and redundant loop cabling. The amplifiers have a changeover facility for spare power amplifier switching. Changeover relays are included with the units. The amplifiers have a 48 V DC back-up supply input.

The digital audio processing can handle three parametric equalization sections and two shelving equalization sections per channel with configurable audio delay.

### Controls and indicators

- 2 x 16-character LCD for status display
- Rotary/push control button
- Mains switch
- Voltage selector for PRS-xPxxx

### Interconnections

- Mains input
- Battery backup input
- Two system network connections
- Two mic/line inputs (four for LBB 4428/00)
- Selectable 100 V, 70 V or 50 V outputs (per channel)
- Fixed 50 V output
- Eight programmable control inputs
- Control output (for each amplifier channel)
- Headphone output
- Spare amplifier connection (for each amplifier channel)

### Certifications and Approvals

Safety	acc. to IEC 60065 / EN 60065
Immunity	acc. to EN 55103-2 / EN 50130-4 / EN 50121-4
Emissions	acc. to EN 55103-1 / FCC-47 part 15B
Emergency	acc. to EN 60849 / EN 54-16 / ISO 7240-16
Maritime	acc. to IEC 60945

**Installation/Configuration Notes**

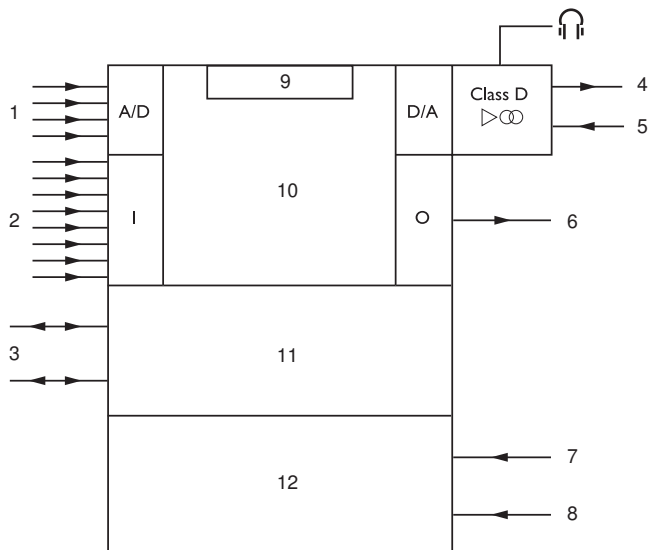

- 1 Audio inputs, 2 x or 4 x
- 2 Control inputs
- 3 Plastic optical fiber network
- 4 Loudspeaker outputs, 1 x, 2 x, 4 x, 8 x
- 5 Spare amplifier input
- 6 Control outputs, 1 x, 2 x, 4 x, 8 x
- 7 Mains input
- 8 48 V backup supply
- 9 Display and control
- 10 Network processor and DSP
- 11 Network redundancy switching
- 12 Power supply

Block diagram

**Parts Included**

Quantity	Component
1	PRS-xPxxx or LBB 4428/00 Power Amplifier
1	Power cord
1	Set of mounting brackets (large) for 19" rack
1	Set of feet
1	Set of connectors

**Technical Specifications**

**Electrical**

**Mains power supply**

Voltage	
PRS-xPxxx	115 / 230 VAC ±10%, 50/60 Hz
LBB 4428/00	100 to 240 VAC ±10%, 50/60 Hz
Power consumption	
PRS-1P500	353 / 39 / 15 W

**Mains power supply**

PRS-2P250	354 / 43 / 16 W
PRS-4P125	350 / 54 / 20 W
LBB 4428/00	433 / 90 / 32 W
* Alarm tone level	
** With pilot tone 15 V	

**Battery power supply**

Voltage	
48 VDC -10% to +20%	
Power consumption	
Pmax -3 dB* / idle** / standby	
PRS-1P500	327 / 29 / 5 W
PRS-2P250	327 / 30 / 5 W
PRS-4P125	332 / 39 / 10 W
LBB 4428/00	397 / 63 / 22 W
* Alarm tone level	
** With pilot tone 15 V	

**Mic/line inputs**

**2 x (4 x for LBB 4428/00)**

Connector	6-pole header for removable screw connector (mono, balanced)
Line	
Frequency response	-3 dB @ 50 Hz and 20 kHz (±1 dB)
S/N	>87 dBA
CMRR	>40 dB @ 1 kHz
Input range	-6 dBV to 6 dBV
Input impedance	22 kohm
Mic	
Frequency response	-3 dB @ 100 Hz and 16 kHz
Nominal input level	-57 dBV
S/N	>62 dBA with 25 dB headroom
CMRR	40 dB at 1 kHz
Input impedance	1360 ohm
Phantom supply	12 V ±1 V @ 15 mA
Input range	-7 dBV to +8 dBV ref nominal input value

**Control inputs**

**8 x**

Connectors	Removable screw terminals
Operation	Closing contact (with supervision)

**Control outputs**

**1 x per amplifier channel**

Connectors	Removable screw terminals
------------	---------------------------

**Performance**

Frequency response	
PRS-xPxxx	60 Hz to 19 kHz (-3 dB)
LBB 4428/00	80 Hz to 19 kHz (-3 dB)
S/N	>85 dB (no pilot tone)
Crosstalk	<80 dB at nominal load for 1 kHz
Distortion	<0.3% (@ 1 kHz) @ 50% of rated output power

<b>Loudspeaker outputs</b>	<b>PRS-1P500</b>
Rated load resistance	20 ohm (100 V); 10 ohm (70 V) 5 ohm (50 V)
Rated load capacitance	250 nF (100 V); 500 nF (70 V) 1000 nF (50 V)
Rated output power (per channel)	500 W (1 min. at 55 °C) 250 W (30 min. at 55 °C, cont. at 30 °C) 125 W (cont. at 55 °C)

Connector 9-pole header for removable screw connector

<b>Loudspeaker outputs</b>	<b>PRS-2P250</b>
Rated load resistance	40 ohm (100 V); 20 ohm (70 V) 10 ohm (50 V)
Rated load capacitance	125 nF (100 V); 250 nF (70 V) ) 500 nF (50 V)
Rated output power (per channel)	250 W (1 min. at 55 °C) 125 W (30 min. at 55 °C, cont. at 30 °C) 60 W (cont. at 55 °C)

Connector 9-pole header for removable screw connector

<b>Loudspeaker outputs</b>	<b>PRS-4P125</b>
Rated load resistance	80 ohm (100 V); 40 ohm (70 V) 20 ohm (50 V)
Rated load capacitance	62 nF (100 V); 125 nF (70 V) ) 250 nF (50 V)
Rated output power (per channel)	125 W (1 min. at 55 °C) 60 W (30 min. at 55 °C, cont. at 30 °C) 30 W (cont. at 55 °C)

Connector 9-pole header for removable screw connector

<b>Loudspeaker outputs</b>	<b>LBB 4428/00</b>
Rated load resistance	166 ohm (100 V); 83 ohm (70 V) 42 ohm (50 V)
Rated load capacitance	30 nF (100 V); 60 nF (70 V) ) 120 nF (50 V)
Rated output power (per channel)	60 W (1 min. at 55 °C) 30 W (30 min. at 55 °C, cont. at 30 °C) 15 W (cont. at 55 °C)

Connector 9-pole header for removable screw connector

#### Mechanical

Dimensions (H x W x D)	
for tabletop use, with feet	92 x 440 x 400 mm (3.6 x 17.3 x 15.7 in)
for 19" rack use, with brackets	88 x 483 x 400 mm (3.5 x 19 x 15.7 in)
in front of brackets	40 mm (1.6 in)
behind brackets	360 mm (14.2 in)

Weight	
PRS-1P500	12.6 kg (27.78 lb)
PRS-2P250	13.6 kg (29.98 lb)
PRS-4P125	16.1 kg (35.49 lb)
LBB 4428/00	14.5 kg (31.97 lb)
Mounting	Standalone; 19"-rack
Color	Charcoal with silver

#### Environmental

Operating temperature	-5 °C to +55 °C (+23 °F to +131 °F)
Storage temperature	-20 °C to +70 °C (-4 °F to +158 °F)
Relative humidity	15% to 90%
Air pressure	600 to 1100 h Pa

#### Ordering Information

<b>PRS-1P500 Power Amplifier 1 x 500 W</b> 1 x 500 W	<b>PRS-1P500</b>
<b>PRS-2P250 Power Amplifier 2 x 250 W</b> 2 x 250 W	<b>PRS-2P250</b>
<b>PRS-4P125 Power Amplifier 4 x 125 W</b> 4 x 125 W	<b>PRS-4P125</b>
<b>LBB 4428/00 Power Amplifier 8 x 60 W</b> 8 x 60 W	<b>LBB4428/00</b>

#### Accessories

<b>LBB 4440/00 Supervision Control Board</b> for use in the power amplifier on each amplifier channel	<b>LBB4440/00</b>
<b>LBB 4441/00 Loudspeaker Supervision Board</b> monitors the integrity of a loudspeaker	<b>LBB4441/00</b>
<b>LBB 4442/00 Line Supervision Set</b> contains the master and slave device for supervision of a single loudspeaker line	<b>LBB4442/00</b>
<b>LBB 4443/00 End of Line (EOL) Supervision Board</b> monitors the integrity of a loudspeaker line	<b>LBB4443/00</b>

## PRS-xBxxx Basic Amplifiers



### Features

- ▶ **High efficiency class-D amplifier channel(s)**
- ▶ **Switched mode power supply**
- ▶ **Local audio inputs**
- ▶ **Mains and battery operation**
- ▶ **Complete supervision**

The basic amplifiers are cost effective alternatives to the regular Praesideo power amplifiers, for situations where no built-in digital signal processing functions, such as equalizers, delay and AVC are required. They do not have a Praesideo network connection. Instead, these amplifiers are connected to the Praesideo network via the PRS-16MCI Multi Channel Interface, which provides the basic amplifier with audio signals and has full control. There are four versions, the PRS-1B500 (1 x 500 W), PRS-2B250 (2 x 250 W), PRS-4B125 (4 x 125 W) and the PRS-8B060 (8 x 60 W).

The basic amplifiers are completely supervised and fault events are reported via the multi channel interface to the Praesideo network controller.

The basic amplifiers provide connections for separate group A and group B loudspeakers for each zone, and support class-A loudspeaker loop wiring. The units should be mounted in a 19"-rack with the included mounting brackets.

### Functions

#### Amplification

The PRS-1B500 is a single channel, 500 W unit, the PRS-2B250 is a two-channel amplifier with 250 W per channel, the PRS-4B125 is a four-channel amplifier with 125 W per channel and the PRS-8B060 is an eight-channel amplifier with 60 W per channel. The power supply is switched mode with low inrush current and the units can run on 48 V, battery stand-by power.

### Connection

The amplifiers have built-in output transformers for driving 70 and 100 V loudspeakers. They have separate overload-protected group A and group B loudspeaker connections, which support class-A loop wiring. The separate A and B groups of each channel can be configured for redundancy. The units connect to the PRS-16MCI Multi Channel Interface for audio, control and supervision, but stand-alone operation is possible.

### Audio

The amplifiers have analog audio line inputs for low priority local audio. Networked audio from the multi channel interface overrides the local audio.

### Security

The units operate both on mains power and on a 48 V battery power supply for emergency back up, with automatic switchover. They supervise both of the power supplies, as well as themselves. They can optionally monitor loudspeakers and their lines, when used together with the PRS-16MCI Multi Channel Interface. Complete channel separation allows one channel of the amplifier to function as a spare amplifier for the other amplifier channel.

The amplifier has overload and short circuit protection. An overheat protection circuit switches off the power stage and activates the fault LED on the front panel if the internal temperature reaches a critical limit.

### Controls and indicators

#### Front

- Two two-color LEDs for mains and battery status
- Four amplifier status/level LEDs (per channel)

#### Back

- Mains on/off switch
- Mains voltage selector
- Rotary volume control for local audio inputs (per channel)

#### Inside

- 70 V / 100 V selection (per channel)

### Interconnection

#### Back

- Mains socket
- Battery backup input
- Two loudspeaker output screw terminals (per channel)
- Spare amplifier input screw terminal (per channel)
- Two RJ45 connectors (per channel)
- Local audio input screw terminal (per channel)

### Certifications and Approvals

Region	Certification
Europe	CE

Safety	acc. to IEC 60065 / EN 60065
Immunity	acc. to EN 55103-2 / EN 50130-4 / EN 50121-4
Emissions	acc. to EN 55103-1 / FCC-47 part 15B
Emergency	acc. to EN 60849 / EN 54-16 / ISO 7240-16
Maritime	acc. to IEC 60945

### Parts Included

Quantity	Component
1	PRS-1B500 Basic Amplifier 1x500 W or PRS-2B250 Basic Amplifier 2x250 W or PRS-4B125 Basic Amplifier 4x125 W or PRS-8B060 Basic Amplifier 8x60 W
2/4/8/16	CAT 5-cables (for PRS-1B500 / PRS-2B250 / PRS-4B125 / PRS-8B060)
1	Power cord
1	Set of mounting brackets (large) for 19" rack
1	Set connectors

### Technical Specifications

#### Electrical

##### Mains power supply

Voltage	115/230 VAC $\pm$ 10%, 50/60 Hz
Power consumption	Pmax -3 dB* / idle** / standby
PRS-1B500	450 / 52 / 17 W
PRS-2B250	378 / 46 / 18 W
PRS-4B125	395 / 62 / 16 W
PRS-8B060	400 / 80 / 16 W
	* Alarm tone level
	** With pilot tone 15 V

##### Battery power supply

Voltage	48 VDC -10% to +20%
Power consumption	Pmax -3 dB* / idle** / standby
PRS-1B500	365 / 34 / 6 W
PRS-2B250	370 / 38 / 6 W
PRS-4B125	375 / 48 / 9 W
PRS-8B060	385 / 62 / 10 W
	* Alarm tone level
	** With pilot tone 15 V

#### Performance

Frequency response	60 Hz to 19 kHz (-3 dB) 80 Hz to 19 kHz (-3 dB, PRS-8B060)
Total harmonic distortion	<0.3% (1kHz) at 50% of rated power
Cross talk	-70 dB (1 kHz) nominal (only multichannel)
Signal-to-noise ratio	>85 dB with pilot tone off

#### Line inputs

Local audio input	0 dBV (symmetrical)
-------------------	---------------------

#### Speaker outputs PRS-1B500

Rated load resistance	20 ohm (100 V); 10 ohm (70 V)
Rated load capacitance	250 nF (100 V); 500 nF (70 V)
Rated output power	500 W (1 min. at 55 °C) 250 W (30 min. at 55 °C, cont. at 30 °C) 125 W (cont. at 55 °C)

#### Speaker outputs PRS-2B250

Rated load resistance	40 ohm (100 V); 20 ohm (70 V)
Rated load capacitance	125 nF (100 V); 250 nF (70 V)
Rated output power (per channel)	250 W (1 min. at 55 °C) 125 W (30 min. at 55 °C, cont. at 30 °C) 60 W (cont. at 55 °C)

#### Speaker outputs PRS-4B125

Rated load resistance	80 ohm (100 V); 40 ohm (70 V)
Rated load capacitance	60 nF (100 V); 125 nF (70 V)
Rated output power (per channel)	125 W (1 min. at 55 °C) 60 W (30 min. at 55 °C, cont. at 30 °C) 30 W (cont. at 55 °C)

#### Speaker outputs PRS-8B060

Rated load resistance	160 ohm (100 V); 80 ohm (70 V)
Rated load capacitance	30 nF (100 V); 60 nF (70 V)
Rated output power (per channel)	60 W (1 min. at 55 °C) 30 W (30 min. at 55 °C, cont. at 30 °C) 15 W (cont. at 55 °C)

#### Mechanical

Dimensions (H x W x D)	
rack use, with brackets	88 x 483 x 400 mm (3.5 x 19 x 15.7 in)
in front of brackets	40 mm (1.6 in)
behind brackets	360 mm (14.2 in)

#### Weight

PRS-1B500	12 kg (26.5 lb)
PRS-2B250	14 kg (30.9 lb)
PRS-4B125	15 kg (33.4 lb)
PRS-8B060	13.7 kg (30.5 lb)

Mounting	19" rack
Color	Charcoal with silver

#### Environmental

Operating temperature	-5 °C to +55 °C (+23 °F to +131 °F)
Storage temperature	-40 °C to +70 °C (-40 °F to +158 °F)
Relative humidity	15% to 90%
Air pressure	600 to 1100 hPa

**Ordering Information**

**PRS-1B500 Basic Amplifier 1 x 500 W**      **PRS-1B500**  
1 x 500 W. Amplifier for connection to PRS-16MCI (multi-channel interface).

**PRS-2B250 Basic Amplifier 2 x 250 W**      **PRS-2B250**  
2 x 250 W. Amplifier for connection to PRS-16MCI (multi-channel interface).

**PRS-4B125 Basic Amplifier 4 x 125 W**      **PRS-4B125**  
4 x 125 W. Amplifier for connection to PRS-16MCI (multi-channel interface).

**PRS-8B060 Basic Amplifier 8 x 60 W**      **PRS-8B060**  
8 x 60 W. Amplifier for connection to PRS-16MCI (multi-channel interface).

## PRS-16MCI Multichannel Interface



### Features

- ▶ Interface to Praesideo basic amplifiers
- ▶ Up to 16 audio channels
- ▶ Redundant fiber optic network connection
- ▶ Control input and output connections
- ▶ Complete supervision

The PRS-16MCI is part of the Praesideo network and acts as an interface to the Praesideo basic amplifiers that do not provide network connectivity. The unit is intended for public address and emergency sound systems. The multichannel interface provides 16 configurable output channels (14 main outputs and two spare outputs). It provides the audio signals to the basic amplifiers and has full control over the amplifiers. It supervises itself and the connected basic amplifiers, and reports fault events to the Praesideo network controller.

The unit should be mounted in a 19"-rack with the included mounting brackets.

### Functions

This unit is the interface between the Praesideo network and the Praesideo basic amplifiers. It can get its power from the amplifiers it is connected to, or from the network. It has 16 audio channels for up to 14 main amplifiers (zones) and two spare amplifiers. These can be assigned from a non-mixing matrix of 28 Praesideo channels. There are connections for 32 control inputs and 16 control outputs.

The interface provides supervision for the unit itself, as well as all connected basic amplifiers. The interface monitors the functions of the amplifiers, and can activate a spare amplifier to replace one that reports a fault. It has loop-through in and outputs, supporting failsafe mode, which pass emergency calls through, even if the unit itself fails. A controller for multiple-line and loudspeaker supervision is a standard component. The interface can be

configured for redundant group A/B switching, or for class-A loop wiring of the connected basic amplifiers. All configuration is done with software over the network.

### Controls and indicators

- 16 two-color LEDs for amplifier channel status
- Two-color LED for network status

### Interconnection

- Two system network connectors
- 32 RJ45 jacks for basic amplifiers
- Female XLR-3 connector for failsafe audio loop-through input
- Male XLR-3 connector for failsafe audio loop-through and supervision
- 32 control inputs on removable Euro-style screw terminals
- 16 control outputs on removable Euro-style screw terminals

### Certifications and Approvals

Region	Certification
Europe	CE
Poland	CNBOP
Safety	acc. to IEC 60065 / EN 60065
Immunity	acc. to EN 55103-2 / EN 50130-4 / EN 50121-4
Emissions	acc. to EN 55103-1 / FCC-47 part 15B
Emergency	acc. to EN 60849 / EN 54-16 / ISO 7240-16
Maritime	acc. to IEC 60945

### Parts Included

Quantity	Component
1	PRS-16MCI Multichannel Interface
1	Set of mounting brackets for 19" rack
1	Set of connectors

### Technical Specifications

Electrical	
Power consumption	12 W (DC)
Performance	
Frequency response	20 Hz to 20 kHz (-3 dB)
Total harmonic distortion	<0.1% (1 kHz)
Cross talk	<-80 dB (1 kHz)
S/N	>85 dB (without pilot tone)
Line input	
Connector	XLR bypass
Line output	
Connector	XLR loop-through
Line output	
Connectors	RJ45 jack (in pairs)

**108 | Digital PA and Emergency Sound | Praesideo System****2**

	0 dBV (symmetrical)
<b>Control inputs</b>	32 x
Connectors	Removable screw terminals
Operation	Closing contact (with supervision)
<b>Control outputs</b>	16 x
Connectors	Removable screw terminals
Operation	Change over contact (SPDT) voltage free relay
Rating	24 V, 1 A
<b>Mechanical</b>	
Dimensions (H x W x D) rack with brackets	88 x 483 x 400 mm (3.5 x 19 x 15.7 in)
in front of brackets	40 mm (1.6 in)
behind brackets	360 mm (14.2 in)
Weight	7 kg (15.4 lb)
Mounting	19" rack
Color	Charcoal with silver
<b>Environmental</b>	
Operating temperature	-5 °C to +55 °C (+23 °F to +131 °F)
Storage temperature	-40 °C to +70 °C (-40 °F to +158 °F)
Humidity	15% to 90%
Air pressure	600 to 1100 hPa

**Ordering Information****PRS-16MCI Multichannel Interface**

a network interface to the Praesideo basic amplifiers.

**PRS-16MCI**

## LBB 4430/00 Call Station Basic



### Features

- ▶ Redundant network connection
- ▶ Power 'ON' indication
- ▶ Status/fault indications
- ▶ Indication that the priority level of destinations is higher than that of the pending announcement
- ▶ Supervision of microphone capsule
- ▶ Stylish and modern design

The call station basic can make manual or pre-recorded announcements to any pre-assigned zones. The call station basic has a microphone on a flexible stem, a push-to-talk button, a speaker, and a headset socket.

The LBB 4430/00 can be extended with up to 16 keypads (LBB 4432/00 or LBB 4434/00), each with eight programmable keys. Extension with a numeric keypad (PRS-CSNKP) is also possible.

### Functions

The call station has a cardioid, supervised microphone on a gooseneck stem with good speech intelligibility. A limiter and a speech filter improve intelligibility and prevent clipping of the audio. It has a volume control for the monitoring speaker and the headset. When it plays a chime or a pre-recorded message, the call station activates its speaker. When a headset is connected, it replaces the microphone and speaker. The call station has its own DSP, and converts between analog and digital audio. The audio processing can include sensitivity adjustment, limiting, and parametric equalization.

Up to 16 call station keypads can connect to the station via a serial communication link. The station provides the power for the keypads. Up to 224 priorities can be assigned to the call station. All configuration can be done via the Praesideo network controller.

The call station is fully supervised and supports fail-safe operation. Even if the Praesideo network controller fails, the call station is still able to put through emergency calls.

### Controls and indicators

- Three status LEDs
- Configurable PTT-key
- Volume control for loudspeaker/headset

### Interconnections

- Two system network connections
- Serial data and power supply interface for call station keypads
- 3.5 mm jack for headset

### Certifications and Approvals

Region	Certification
Europe	CE
Poland	CNBOP
Safety	acc. to IEC 60065 / EN 60065
Immunity	acc. to EN 55103-2 / EN 50130-4 / EN 50121-4
Emissions	acc. to EN 55103-1 / FCC-47 part 15B
Emergency	acc. to EN 60849 / EN 54-16 / ISO 7240-16
Maritime	acc. to IEC 60945

### Installation/Configuration Notes

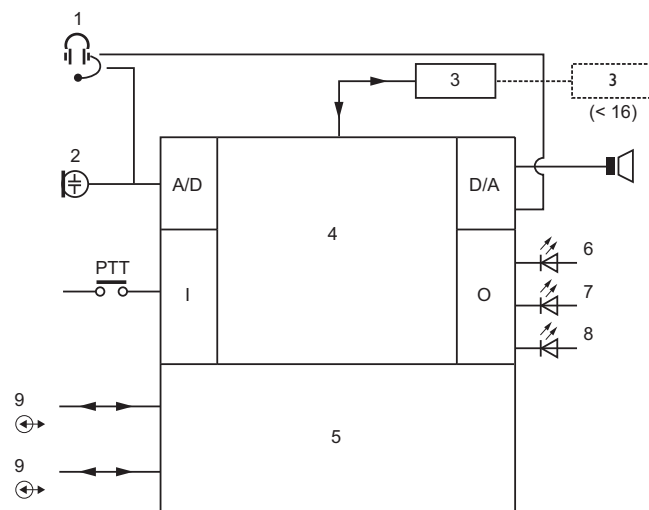

- 1 Headset
- 2 Microphone
- 3 Keypad(s)
- 4 Network processor and DSP
- 5 Network redundancy switching

## 110 | Digital PA and Emergency Sound | Praesideo System

2

- 6 Power/error
- 7 Call station status
- 8 Network status
- 9 Network connections

**Parts Included****Quantity Component**

1	LBB 4430/00 Call Station Basic
1	Flat cable

**Technical Specifications****Electrical**

External power supply	18 to 56 VDC
Power consumption	4.4 W (DC) excluding keypads

**Microphone**

Nominal acoustic input level	75 to 90 dB SPL
S/N	>60 dB at 85 dB SPL
Frequency response	340 Hz to 14 kHz (-3 dB)

**Loudspeaker**

S/N	80 dB at max. output
Sound pressure level	85 dB (SPL) at 0.5 m and 1 kHz

**Headset**

Connector	3.5 mm jack
Recommended type	Hosiden HBH 0058

**Mechanical**

Dimensions (H x W x D)	90 x 160 x 200 mm
Weight	0.95 kg (2.1 lb)
Mounting	Tabletop
Color	Charcoal
Length of mic stem	380 mm

**Environmental**

Operating temperature	-5 °C to +45 °C (+23 °F to +113 °F)
Storage temperature	-20 °C to +70 °C (-4 °F to +158 °F)
Humidity	15% to 90%
Air pressure	600 to 1100 hPa

**Ordering Information**

<b>LBB 4430/00 Call Station Basic</b>	<b>LBB4430/00</b>
has a microphone on a flexible stem, a push-to-talk button, a speaker, and a headset socket.	

**Accessories**

<b>LBB 4432/00 Call Station Keypad</b>	<b>LBB4432/00</b>
has eight programmable buttons, each with a two-color status LED.	

<b>LBB 4434/00 Call Station Keypad Kit</b>	<b>LBB4434/00</b>
used in combination with a call station kit or call station basic to make manual or pre-recorded announcements to any assigned zones, or to execute pre-defined actions.	

<b>PRS-CSNKP Numeric Keypad</b>	<b>PRS-CSNKP</b>
can be used for user access, zone and zone group selection. LCD for user feedback.	

## LBB 4432/00 Call Station Keypad



### Features

- ▶ Eight freely programmable selection keys
- ▶ Serial data and power interface to call station basic
- ▶ Up to 16 keypads can be connected to one call station basic
- ▶ Activation indicator for each key
- ▶ Stylish and modern design

The call station keypad is used in combination with the call station basic to make manual or pre-recorded announcements to any assigned zones, to select the zones or to execute pre-defined actions. The call station keypad has eight programmable buttons, each with a two-color status LED.

### Functions

The keys of the call station keypad can be programmed for actions, such as:

- Controlling functions: selection recall, call activation, cancel selection, BGM off, BGM volume control, fault acknowledgement, etc.
- Selecting sources: BGM channel, pre-recorded messages, attention and alarm tones
- Selecting destinations: zones and zone groups

The keys can be programmed for different modes of operation, such as momentary or toggle. Each key has one two-color status LED beside it. Beside each LED is a transparent, removable tab that can hold a function or zone label for the key. Safety covers to prevent accidental activation of the keys are available as an option.

The keypad gets its power from the call station it is connected to.

### Controls and indicators

- Eight function keys
- Eight two-color LEDs

### Interconnections

- Two serial data and power connections

### Certifications and Approvals

Region	Certification
Europe	CE
Poland	CNBOP
Safety	acc. to IEC 60065 / EN 60065
Immunity	acc. to EN 55103-2 / EN 50130-4 / EN 50121-4
Emissions	acc. to EN 55103-1 / FCC-47 part 15B
Emergency	acc. to EN 60849 / EN 54-16 / ISO 7240-16
Maritime	acc. to IEC 60945

### Parts Included

Quantity	Component
1	LBB 4432/00 Call Station Keypad
1	Flat cable
1	Coupling bracket
1	Set of text labels

### Technical Specifications

#### Electrical

Power consumption	1.1 W (DC)
-------------------	------------

#### Mechanical

Dimensions (H x W x D)	70 x 95 x 200 mm (2.8 x 3.7 x 7.9 in)
Weight	0.3 kg (0.7 lb)
Mounting	Bracket attachment to a call station or other keypad
Color	Charcoal

#### Environmental

Operating temperature	-5 °C to +45 °C (+23 °F to +113 °F)
Storage temperature	-20 °C to +70 °C (-4 °F to +158 °F)
Humidity	15% to 90%
Air pressure	600 to 1100 hPa

**112 | Digital PA and Emergency Sound | Praesideo System**

---

**Ordering Information**

<b>LBB 4432/00 Call Station Keypad</b>	<b>LBB4432/00</b>
--	-------------------

has eight programmable buttons, each with a two-color status LED.

---

**Accessories**

<b>LBB 4436/00 Set of Key Covers (10 pcs)</b>	<b>LBB4436/00</b>
---	-------------------

10 key covers and 10 replacement lenses

2

## PRS-CSNKP Numeric Keypad



### Features

- ▶ **Numeric keypad for zone selection and user access**
- ▶ **Serial data and power interface to call-station basic**
- ▶ **Can be combined with normal call-station keypads**
- ▶ **LCD for user feedback**
- ▶ **Stylish and modern design**

The Call-Station Numeric Keypad is used in combination with a basic or remote call-station. The call-station provides the microphone and press-to-talk key, while the numeric keypad can be used for user access, zone and zone group selection. It works together with call-station keypads for pre-configured actions. The built-in LCD provides feedback to the user.

### Functions

The call-station numeric keypad has a 12-key numeric keypad, providing a telephone-like user interface with \*, # and 0...9 keys. A single numeric keypad connects directly to a basic or remote call-station and subsequently up to 15 other keypads can be linked for controlling functions. It is mechanically fixed to the call-station. The numeric keypad can be configured for the following functions:

- User access to the call-station with user number and PIN, configurable for multiple users, with time-out and manual lock
- Selecting zones and zone groups as destinations for calls; up to eight zones and/or zone groups can be entered into a string.

The LCD gives feedback to the user about the selections and the status of the selected zones and zone groups.

The keypad gets its power supply from the connected call-station. It is configured via the Praesideo network controller (web browser interface).

### Controls and indicators

- 12 numeric keys
- 2 x 16 character LCD with backlight
- LCD brightness adjustment
- LCD contrast adjustment

### Interconnections

- Flat-cable connection to call-station
- Flat-cable connection to next keypad

### Certifications and Approvals

Region	Certification
Europe	CE
Safety	acc. to IEC 60065 / EN 60065
Immunity	acc. to EN 55103-2 / EN 50130-4 / EN 50121-4
Emissions	acc. to EN 55103-1 / FCC-47 part 15B
Emergency	acc. to EN 60849 / EN 54-16 / ISO 7240-16
Maritime	acc. to IEC 60945

### Parts Included

Quantity	Component
1	PRS-CSNKP Numeric Keypad
1	Flat-cable
1	Coupling bracket

### Technical Specifications

#### Electrical

Power consumption	1.8 W (DC)
-------------------	------------

#### Mechanical

Dimensions (H x W x D)	70 x 95 x 200 mm (2.8 x 3.7 x 7.9 in)
Weight	0.4 kg (0.9 lb)
Mounting	Bracket attachment to a call-station or other keypad
Color	Charcoal

#### Environmental

Operating temperature	-5 °C to +45 °C (+23 °F to +113 °F)
Storage temperature	-20 °C to +70 °C (-4 °F to +158 °F)
Relative humidity	15% to 90%
Air pressure	600 to 1100 hPa

---

### Ordering Information

**PRS-CSNKP Numeric Keypad**

can be used for user access, zone and zone group selection. LCD for user feedback.

**PRS-CSNKP**

2

## LBB 4433/00 Call Station Kit

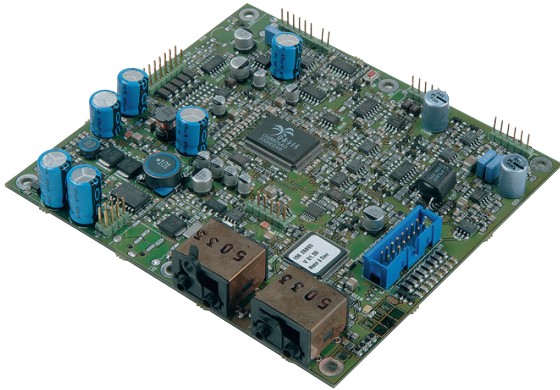

### Features

- ▶ Redundant network connection
- ▶ Power 'ON' outputs
- ▶ Status/fault outputs
- ▶ Output for a monitoring loudspeaker
- ▶ Priority indication of busy target zones
- ▶ Microphone supervision

The call station kit is used to make custom-made call stations, with the same functionality as the LBB 4430/00 Call Station Basic. The call station contains a built-in limiter and speech filter for improved intelligibility. An external power supply can be connected to the call station kit. Two supervised control inputs provide power supply status information.

The LBB 4433/00 can be extended with up to 16 keypads (LBB 4432/00 or LBB 4434/00), each with eight programmable keys. Extension with a numeric keypad (PRS-CSNKP) is also possible.

### Functions

The call station kit has a limiter and a speech filter. This improves intelligibility and prevents clipping of the audio. A potentiometer for volume control of the monitoring speaker and the headset can be connected. When it plays a chime or a pre-recorded message, the call station activates its speaker. The call station has its own DSP, and converts between analog and digital audio. The audio processing includes sensitivity adjustment, limiting, and parametric equalization.

Up to 16 call station keypads can connect to the station via a serial communication link. The call station provides the power for the keypads. Up to 224 priorities can be assigned to the call station. All configuration can be done via the Praesideo network controller.

The call station kit is fully supervised and supports fail-safe operation. Even if the Praesideo network controller fails, the call station is still able to put through emergency calls.

### Controls and indicators

These must be supplied by the installer.

### Interconnections

- Two network connectors (system bus)
- Backup supply input and 2 control inputs
- Serial data and power supply interface for call station keypads
- Microphone
- Loudspeaker
- Headset
- Volume control for loudspeaker/headset
- Control input (for PTT)
- Five control outputs (for status LEDs)

### Certifications and Approvals

Region	Certification
Europe	CE
Safety	acc. to IEC 60065 / EN 60065
Immunity	acc. to EN 55103-2
Emissions	acc. to EN 55103-1 / FCC-47 part 15B
Emergency	acc. to EN 60849
Maritime	acc. to IEC 60945

### Installation/Configuration Notes

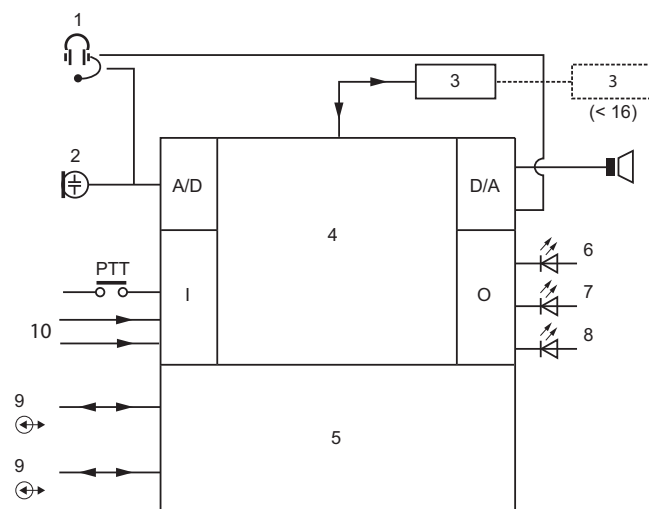

## 116 | Digital PA and Emergency Sound | Praesideo System

2

1	Headset
2	Microphone
3	Keypad(s)
4	Network processor and DSP
5	Network redundancy switching
6	Power/error
7	Call station status
8	Network status
9	Network connections
10	Control inputs

**Parts Included****Quantity Component**

1	LBB 4433/00 Call Station Kit
1	Set of connectors

**Technical Specifications****Electrical**

Power consumption	6.2 W (DC) excl. indicators and keypads
<b>Mic input</b>	1 x
Sensitivity	-57 to -42 dBV
S/N	>60 dB at -48 dBV
Frequency response	340 Hz to 14 kHz (-3 dB)
<b>Loudspeaker output</b>	1 x
S/N	80 dB $\pm$ 3 dB at max.
Impedance	8 to 32 ohm
Power	100 mW typ., 300 mW max.
<b>Headset</b>	1 x
Impedance	0.5 to 5 kohm
Input sensitivity	-57 to -42 dBV/Pa ( $\pm$ 3 dB)
Earphone impedance	>16 ohm
<b>Status outputs</b>	5 x open collector / drain
Max. current (internal)	10 mA per pin; 30 mA total
Max. voltage	56 V per pin
Max sink current	100 mA per output pin
<b>Control inputs</b>	2 x closing contact (with supervision)
<b>Mechanical</b>	
Dimensions (H x W x D)	20 x 130 x 118 mm (0.8 x 5.1 x 4.6 in)
Weight	120 g (0.26 lb)
Mounting	PCB with 6 mounting holes
<b>Environmental</b>	
Operating temperature	-5 °C to +55 °C (+23 °F to +131 °F)
Storage temperature	-40 °C to +70 °C (-40 °F to +158 °F)
Humidity	15% to 90%
Air pressure	600 to 1100 hPa

**Ordering Information**

<b>LBB 4433/00 Call Station Kit</b>	<b>LBB4433/00</b>
used to make custom-made call stations	

**Accessories**

<b>LBB 4434/00 Call Station Keypad Kit</b>	<b>LBB4434/00</b>
used in combination with a call station kit or call station basic to make manual or pre-recorded announcements to any assigned zones, or to execute pre-defined actions.	

<b>LBB 4432/00 Call Station Keypad</b>	<b>LBB4432/00</b>
has eight programmable buttons, each with a two-color status LED.	

<b>PRS-CSNKP Numeric Keypad</b>	<b>PRS-CSNKP</b>
can be used for user access, zone and zone group selection. LCD for user feedback.	

## LBB 4434/00 Call Station Keypad Kit

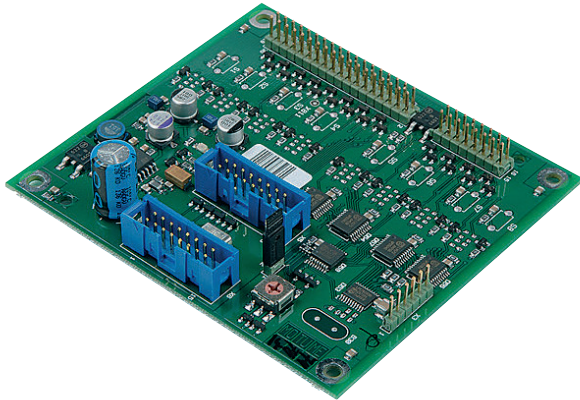

### Features

- ▶ **Eight programmable control inputs linked to 16 outputs**
- ▶ **Two serial interfaces to call stations or other keypads**
- ▶ **Up to 16 keypads can be connected to one call station**

The call station keypad kit is used in combination with a call station kit or call station basic to make manual or pre-recorded announcements to any assigned zones, or to execute pre-defined actions. It is functionally equivalent to the LBB 4432/00 Call Station Keypad. One of the main applications is the development of fireman's panels. However, since the call station keypad has eight programmable input connections, each with two associated output connections; it is well suited for other control applications.

### Functions

The key inputs of the kit can be programmed for actions such as:

- Controlling functions: selection recall, call activation, cancel selection, BGM off, BGM volume control, fault acknowledgement, etc.
- Selecting sources: BGM channel, pre-recorded messages, attention and alarm tones
- Selecting destinations: zones and zone groups

Each key input of the PCB has two functionally related outputs designed to drive a two-color LED, but which can be used for other purposes. Once a control input is used for a function, the two control outputs will be linked to the specific action. Call macros can also be assigned to inputs.

The PCB also has interfaces for serial connections to a call station or other keypads. The keypad gets its power from the call station, it is connected to. The key inputs can be programmed for different modes of operation, such as momentary or toggle.

### Interconnections

- Eight control inputs
- 16 control outputs
- Two serial data and power connections

### Certifications and Approvals

Region	Certification
Europe	CE
Safety	acc. to IEC 60065 / EN 60065
Immunity	acc. to EN 55103-2
Emissions	acc. to EN 55103-1 / FCC-47 part 15B
Emergency	acc. to EN 60849
Maritime	acc. to IEC 60945

### Parts Included

Quantity	Component
1	LBB 4434/00 Call Station Keypad Kit
1	Flat cable
1	Set of connectors

### Technical Specifications

#### Electrical

Power consumption	1.2 W (DC) excl. indicators
<b>Control inputs</b>	8 x
Max. current	0.5 mA
Max. voltage	3.3 V (with 10 kohm pull-up)
<b>Control outputs</b>	8 x 2 open collectors
Max. current	100 mA
Max. voltage	30 V

#### Mechanical

Dimensions (H x W x D)	20 x 90 x 100 mm (0.8 x 3.5 x 3.9 in)
Weight	55 g (0.12 lb)
Mounting	PCB with 4 mounting holes

#### Environmental

Operating temperature	-5 °C to +55 °C (+23 °F to +131 °F)
Storage temperature	-20 °C to +70 °C (-4 °F to +158 °F)
Humidity	15% to 90%
Air pressure	600 to 1100 hPa

---

### Ordering Information

**LBB 4434/00 Call Station Keypad Kit**

used in combination with a call station kit or call station basic to make manual or pre-recorded announcements to any assigned zones, or to execute pre-defined actions.

**LBB4434/00**

## PRS-CSI Call Station Interface



### Features

- ▶ Connects a remote call station to the Praesideo network via CAT-5 cable (up to 1 km)
- ▶ Powered by the Praesideo network and/or local power supply
- ▶ Two supervised control inputs
- ▶ Built-in DSP for audio processing functions
- ▶ Complete supervision of the unit

The PRS-CSI is an interface between a single remote call station, PRS-CSR, or a remote call station kit, PRS-CSRK, and the fiber optical Praesideo network. It uses CAT-5 cable for the connection to the remote call station. The CAT-5 cable, carrying digital audio and control data, can be as long as 1 km. The length of the CAT-5 cable is not a part of the Praesideo optical network length. This considerably increases the overall possible length of the optical network, especially in cases, where the call station is located far from the rest of the system.

The call station interface can get its power from the Praesideo network, and/or from a local power supply. It is fully supervised.

### Functions

The interface can connect a single PRS-CSR remote call station or PRS-CSRK remote call station kit to a Praesideo system with up to 1 km of CAT-5 cable.

The interface is fully digital, supporting high-quality sound with a built-in DSP for audio processing of the remote call station. It supports complete supervision of itself, the call station, and the connection, as well as of two control inputs. It supports the fail safe mode of remote call stations, allowing them to put through emergency calls, even if the network controller fails. The unit is configured via the network controller.

### Controls and indicators

- Two LED indicators for power and network status
- Two jumpers (below cover) to separate power supply of call station interface and remote call station

### Interconnectors

- Two Praesideo network connectors
- RJ45 connector for CAT-5 connection
- Kycon type (lockable) connector for power and two control inputs

### Certifications and Approvals

Region	Certification
Europe	CE
Safety	acc. to IEC 60065 / EN 60065
Immunity	acc. to EN 55103-2 / EN 50130-4 / EN 50121-4
Emissions	acc. to EN 55103-1 / FCC-47 part 15B
Emergency	acc. to EN 60849 / EN 54-16 / ISO 7240-16
Maritime	acc. to IEC 60945

### Installation/Configuration Notes

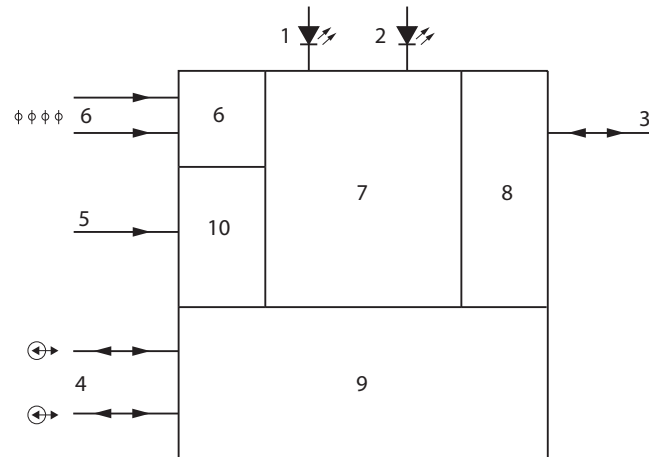

- 1 Fault LED
- 2 Power LED
- 3 CAT-5
- 4 POF
- 5 External (back-up) power 18-56 V
- 6 Control inputs
- 7 Network processor and DSP
- 8 UTP interface

**120 | Digital PA and Emergency Sound | Praesideo System**

- 9 Network redundancy switching
- 10 Power supply

**2****Parts Included****Quantity Component**

1	PRS-CSI Call Station Interface
1	Power supply connector

**Technical Specifications****Electrical**

External power supply	18 to 56 VDC
Power consumption	3.7 W
Control inputs	2 x
Operation	Closing contact (with supervision)

**Mechanical**

Dimensions (H x W x D)	27 x 243 x 80 mm without bracket (1.1 x 9.6 x 3.1 in) 34 x 243 x 84 mm with bracket (1.3 x 9.6 x 3.3 in)
Weight	0.7 kg (1.5 lb)
Mounting	Bracket (2 screws)
Color	Charcoal

**Environmental**

Operating temperature	-5 °C to +55 °C (+23 °F to +131 °F)
Storage temperature	-20 °C to +70 °C (-4 °F to +158 °F)
Humidity	15% to 90%
Air pressure	600 to 1100 hPa

**Ordering Information**

<b>PRS-CSI Call Station Interface</b> an interface between a single remote call station, PRS-CSR, or a remote call station kit, PRS-CSRK, and the fiber optical Praesideo network.	<b>PRS-CSI</b>
---	----------------

**Accessories**

<b>PRS-CSR Call Station Remote</b> same functionality as the basic call station, LBB 4430/00, but it uses CAT-5 cable for its connection to the Praesideo network	<b>PRS-CSR</b>
<b>PRS-CSRK Call Station Remote Kit</b> same functionality as the remote call station, PRS-CSR, but without its housing and other components	<b>PRS-CSRK</b>

## PRS-CSR Call Station Remote



### Features

- ▶ Connects to call station interface via CAT-5 cable
- ▶ Up to 1 km from Praesideo optical network
- ▶ Uses standard Praesideo keypads for extension
- ▶ Built-in limiter
- ▶ Powered via CAT-5 and/or local power supply
- ▶ Complete supervision

The PRS-CSR is a call station with the same functionality as the basic call station, LBB 4430/00, but it uses CAT-5 cable for its connection to the Praesideo network. It connects, one-to-one, to the call station interface, PRS-CSI, which is part of the Praesideo optical network. The CAT-5 cable, carrying digital audio and control data, can be as long as 1 km. The length of the CAT-5 cable is not a part of the Praesideo optical network length. This considerably increases the overall possible length of the optical network.

The PRS-CSR can be extended with up to 16 keypads (LBB 4432/00 or LBB 4434/00), each with eight programmable keys. Extension with a numeric keypad (PRS-CSNKP) is also possible.

### Functions

The call station has a cardioid, supervised microphone on a gooseneck stem with good speech intelligibility. A limiter and a speech filter improve intelligibility and prevent clipping of the audio. It has a volume control for the monitoring speaker and the headset. When it plays a chime or a pre-recorded message, the call station activates its speaker. When a headset is connected, it replaces the microphone and speaker.

The remote call station connects via a CAT-5 cable to an PRS-CSI unit, which interfaces it to the Praesideo optical network. The call station gets its power from the interface unit via the CAT-5 cable, but is also equipped with a local power supply connection for extreme cases with a very long cable and many keypads.

Up to 16 call station keypads can connect to the station via a serial communication link. The call station provides the power for the keypads. Up to 224 priorities can be assigned to the call station. All configuration can be done via the Praesideo network controller.

The remote call station is fully supervised and supports fail-safe operation. Even if the Praesideo network controller fails, the call station is still able to put through emergency calls.

### Controls and indicators

- Three status LEDs
- Configurable PTT-key
- Volume control for loudspeaker/headset

### Interconnections

- RJ45 connector for CAT-5 connection
- Serial data and power supply interface for call station keypads
- Kycon type (lockable) connector for power and two control inputs
- 3.5 mm jack for headset/headphone

### Certifications and Approvals

Region	Certification
Europe	CE
Safety	acc. to IEC 60065 / EN 60065
Immunity	acc. to EN 55103-2 / EN 50130-4 / EN 50121-4
Emissions	acc. to EN 55103-1 / FCC-47 part 15B
Emergency	acc. to EN 60849 / EN 54-16 / ISO 7240-16
Maritime	acc. to IEC 60945

122 | Digital PA and Emergency Sound | Praesideo System

2

**Installation/Configuration Notes**

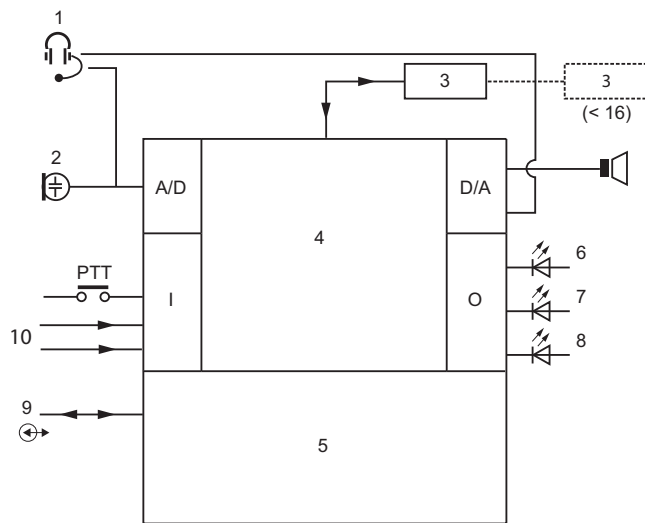

- 1 Headset
- 2 Microphone
- 3 Keypad(s)
- 4 Network processor and DSP
- 5 Network redundancy switching
- 6 Power/error
- 7 Call station status (two-color)
- 8 Network status
- 9 Data connection (CAT-5)
- 10 Control input

**Parts Included**

Quantity	Component
1	PRS-CSR Call Station Remote
1	Flat cable

**Technical Specifications**

**Electrical**

External power supply	18 to 56 VDC
Power consumption	2.9 W at 48 V without keypads

**Microphone**

Nominal acoustic input level	75 to 90 dB SPL
S/N	> 60 dB at 85 dB SPL
Frequency response	340 Hz to 14 kHz (-3 dB)

**Loudspeaker**

S/N	80 dB at max.
Sound pressure level	85 dB (SPL) at 0.5 m and 1 kHz

**Headset**

Connector	3.5 mm jack
Recommended type	Hosiden HBH 0058

**Control inputs**

Operation	Closing contact (with supervision)
-----------	------------------------------------

**Mechanical**

Dimensions (H x W x D)	90 x 160 x 200 mm (3.5 x 6.3 x 7.9 in)
Length of goose neck	380 mm (15 in)
Weight	1 kg (2.2 lb)
Mounting	Standalone
Color	Charcoal

**Environmental**

Operating temperature	-5 °C to +45 °C (+23 °F to +113 °F)
Storage temperature	-20 °C to +70 °C (-4 °F to +158 °F)
Humidity	15% to 90%
Air pressure	600 to 1100 hPa

**Ordering Information**

<b>PRS-CSR Call Station Remote</b> same functionality as the basic call station, LBB 4430/00, but it uses CAT-5 cable for its connection to the Praesideo network	<b>PRS-CSR</b>
--	----------------

**Accessories**

<b>PRS-CSI Call Station Interface</b> an interface between a single remote call station, PRS-CSR, or a remote call station kit, PRS-CSRK, and the fiber optical Praesideo network.	<b>PRS-CSI</b>
---	----------------

<b>LBB 4432/00 Call Station Keypad</b> has eight programmable buttons, each with a two-color status LED.	<b>LBB4432/00</b>
---	-------------------

<b>LBB 4434/00 Call Station Keypad Kit</b> used in combination with a call station kit or call station basic to make manual or pre-recorded announcements to any assigned zones, or to execute pre-defined actions.	<b>LBB4434/00</b>
--	-------------------

<b>PRS-CSNKP Numeric Keypad</b> can be used for user access, zone and zone group selection. LCD for user feedback.	<b>PRS-CSNKP</b>
---	------------------

## PRS-CSRK Call Station Remote Kit

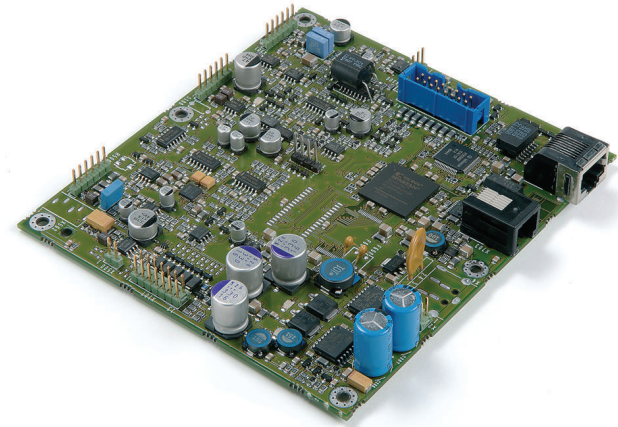

### Features

- ▶ Connects to call station interface via CAT-5 cable
- ▶ Up to 1 km from Praesideo optical network
- ▶ Uses standard Praesideo keypads for extension
- ▶ Built-in limiter
- ▶ Powered via CAT-5 and/or local power supply
- ▶ Complete supervision

The PRS-CSRK is a PCB with the same functionality as the remote call station, PRS-CSR, but without its housing and other components. It is for the construction of custom applications. It connects via a CAT-5 cable, one-to-one, to the call station interface, PRS-CSI, which is part of the Praesideo optical network. The CAT-5 cable, carrying digital audio and control data, can be as long as 1 km. The length of the CAT-5 cable is not a part of the Praesideo optical network length. This considerably increases the overall possible length of the optical network.

The PRS-CSR can be extended with up to 16 keypads (LBB 4432/00 or LBB 4434/00), each with eight configurable keys. Extension with a numeric keypad (PRS-CSNKP) is also possible.

### Functions

The call station has a connection for a supervised microphone. A limiter and a speech filter improve intelligibility and prevent clipping of the audio. It has a volume control for the monitoring speaker and the headset. When it plays a chime or a pre-recorded message, the call station activates its speaker. When a headset is connected, it replaces the microphone and

speaker. The call station has its own DSP, and converts between analog and digital audio. The audio processing can include sensitivity adjustment, limiting, and parametric equalization.

The kit connects via a CAT-5 cable to an PRS-CSI unit, which interfaces it to the Praesideo optical network. The cable can be up to 1 kilometer long. The station gets its power from the interface unit via the CAT-5 cable, but is also equipped with a local power supply connection for extreme cases with a very long cable and many keypads.

Up to 16 call station keypads can connect to the station via a serial communication link. The call station provides the power for the keypads. Up to 224 priorities can be assigned to the call station. All configuration can be done via the Praesideo network controller.

The remote call station is fully supervised and supports fail-safe operation. Even if the Praesideo network controller fails, the call station is still able to put through emergency calls.

### Interconnections

- External power supply input and 2 control inputs
- Serial data and power supply interface for call station keypads
- Microphone
- Loudspeaker
- Headset
- Volume control for loudspeaker/headset
- Control input (for PTT)
- Three control outputs (for status LEDs)

### Certifications and Approvals

Region	Certification
Europe	CE
Safety	acc. to IEC 60065 / EN 60065
Immunity	acc. to EN 55103-2
Emissions	acc. to EN 55103-1 / FCC-47 part 15B
Emergency	acc. to EN 60849
Maritime	acc. to IEC 60945

**Installation/Configuration Notes**

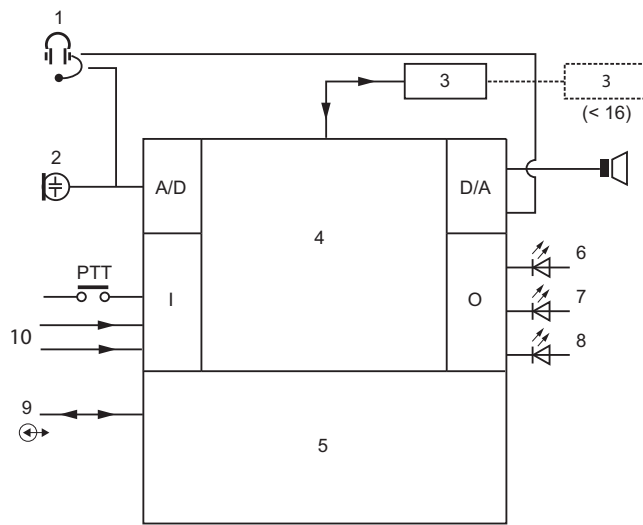

- 1 Headset
- 2 Microphone
- 3 Keypad(s)
- 4 Network processor and DSP
- 5 Network redundancy switching
- 6 Power/error
- 7 Call station status (two-color)
- 8 Network status
- 9 Data connection (CAT-5)
- 10 Control input

**Parts Included**

Quantity	Component
1	PRS-CSRK Call Station Remote Kit
1	Set of connectors

**Technical Specifications**

Electrical	
Power consumption	4 W at 48 V without keypads
External power supply	18 to 56 VDC
Microphone	
Nominal acoustic input level	75 to 90 dB SPL
SNR	> 60 dB at 85 dB SPL
Frequency response	340 Hz to 14 kHz (-3 dB)
Loudspeaker	
SNR	80 dB at max.
Sound pressure level	85 dB (SPL) at 0.5 m and 1 kHz
Headset	
Impedance	0.5 to 5 kohm
Input sensitivity	-57 to -42 dBV/Pa (±3 dB)
Earphone impedance	>16 ohm

<b>Status outputs</b>	5 x open collector / drain
Max. current (internal)	10 mA per pin; 30 mA total
Max. voltage	56 V per pin
Max sink current	100 mA per output pin
<b>Control inputs</b>	2 x
Operation	Closing contact (with supervision)
Mechanical	
Dimensions (H x W x D)	20 x 130 x 118 mm (0.8 x 5.1 x 4.6 in)
Weight	120 g (0.26 lb)
Mounting	PCB 6 holes
Environmental	
Operating temperature	-5 °C to +55 °C (+23 °F to +131 °F)
Storage temperature	-20 °C to +70 °C (-4 °F to +158 °F)
Humidity	15% to 90%
Air pressure	600 to 1100 hPa

**Ordering Information**

<b>PRS-CSRK Call Station Remote Kit</b> same functionality as the remote call station, PRS-CSR, but without its housing and other components	<b>PRS-CSRK</b>
Accessories	
<b>PRS-CSI Call Station Interface</b> an interface between a single remote call station, PRS-CSR, or a remote call station kit, PRS-CSRK, and the fiber optical Praesideo network.	<b>PRS-CSI</b>
<b>LBB 4434/00 Call Station Keypad Kit</b> used in combination with a call station kit or call station basic to make manual or pre-recorded announcements to any assigned zones, or to execute pre-defined actions.	<b>LBB4434/00</b>
<b>LBB 4432/00 Call Station Keypad</b> has eight programmable buttons, each with a two-color status LED.	<b>LBB4432/00</b>
<b>PRS-CSNKP Numeric Keypad</b> can be used for user access, zone and zone group selection. LCD for user feedback.	<b>PRS-CSNKP</b>

## PRS-CRF Call Stacker



### Features

- ▶ Records calls for automatic playback to previously occupied zones (call stacker)
- ▶ Acoustic feedback suppression by recording a call with delayed broadcast (time shifter)
- ▶ Possibility to monitor a call before broadcasting
- ▶ Records and/or plays back up to eight calls simultaneously
- ▶ Stores up to 16 calls
- ▶ Connects directly to Praesideo network

The Call Stacker is a small unit that records calls that cannot be sent to all required zones because some are occupied by a higher priority call. The unit can store up to 16 calls in high-quality format with a maximum of three minutes for each call, including chimes and pre-recorded messages. Playback of a call can start while it is still being recorded. The unit can record and/or playback up to eight calls simultaneously.

More units can be added to a system in order to increase the number of recordable calls. Units can be connected to the Praesideo network at any place.

### Functions

The functions of the call stacker are configured as part of a call macro in Praesideo. Here it is configured whether a call will be recorded for playback later in case zones are occupied or the call is being overruled in some zones.

When these zones become available again, the call is automatically repeated to these remaining zones, to all at once or cascaded to each zone individually.

After a call is finished completely, it will be deleted from memory.

The unit has a configurable time-out period to delete outdated unsend calls.

The call stacker can also be used as time shifter to avoid acoustic feedback from a loudspeaker to the active microphone. The call is recorded and broadcast after the recording has finished. The call can be pre-monitored before broadcast with the option to cancel the call.

Time shifting and call stacking can be combined.

Logging of the call and all its playbacks is supported, but the recorded calls do not survive a power down and are not supervised, so the call stacker function should not be relied upon for emergency calls.

The unit is configurable via the Praesideo network controller (web browser interface).

### Controls and indicators

- Two LED indicators for power and network status

### Interconnections

- Two Praesideo network connectors
- RJ11 service connector (JTAG)

### Certifications and Approvals

Region	Certification
Europe	CE
Safety	acc. to IEC 60065 / EN 60065
Immunity	acc. to EN 55103-2 / EN 50130-4 / EN 50121-4
Emissions	acc. to EN 55103-1 / FCC-47 part 15B
Emergency	acc. to EN 60849 / EN 54-16 / ISO 7240-16
Maritime	acc. to IEC 60945

### Parts Included

Quantity	Component
1	PRS-CRF Call Stacker
1	Mounting bracket

### Technical Specifications

#### Electrical

Power consumption	4.2 W
-------------------	-------

#### Performance

Frequency response	20 Hz to 20 kHz (-3 dB)
S/N	> 85 dB
Crosstalk	<-85 dB

**126 | Digital PA and Emergency Sound | Praesideo System****Mechanical**

## Dimensions (H x W x H)

Without bracket	27 x 243 x 80 mm (1.1 x 9.6 x 3.1 in)
With bracket	34 x 243 x 84 mm (1.3 x 9.6 x 3.3 in)
Weight	0.7 kg (1.5 lb)
Mounting	Bracket (two screws)
Color	Charcoal

**Environmental**

Operating temperature	-5 °C to +55 °C (+23 °F to +131 °F)
Storage temperature	-20 °C to +70 °C (-4 °F to +158 °F)
Relative humidity	15 % to 90 %
Air pressure	600 to 1100 hPa

**Ordering Information****PRS-CRF Call Stacker**

unit that records calls that cannot be sent to all required zones because some are occupied by a higher priority call.

**PRS-CRF**

## PRS-1AIP1 IP Audio Interface



### Features

- ▶ **All-in-one solution for audio transport on IP-networks**
- ▶ **Supervised control inputs and outputs**
- ▶ **Supports re-broadcasting**
- ▶ **Configurable audio delay on the output for loudspeaker alignment**
- ▶ **Easy to install and configure via standard web-browser**
- ▶ **EN 60849 compliant IP solution**

The PRS-1AIP1 is a universal, IP-based audio device supporting VoIP and Audio over IP applications. It is an ideal solution for bridging audio and contact closures over long distance LAN and WAN networks, e.g. in shopping malls, tunnels, in and between railway stations. It extends and interfaces to Praesideo and non-network based traditional public address systems without the need for a PC during operation.

The unit has analog audio inputs and outputs for easy interfacing with optional pilot-tone supervision for emergency sound purposes. One audio input can be switched to microphone sensitivity with built-in microphone supervision. Also, the control inputs offer cable and connection supervision.

Control inputs and outputs can be used to set up an audio connection to start a remote call, but also to pass remote fault events to the system controller.

### Functions

#### Audio

Multiple audio formats are supported: single channel, full duplex 16-bit PCM or G.711 for very low latency, and two-channel send or receive MP3 for high quality audio with various sample rates and compression settings.

The unit provides two balanced line inputs and two balanced line outputs. One of the inputs can be configured as balanced microphone input with a phantom power supply for electret / condenser microphones and microphone connection supervision. The output level is configurable.

Audio connection supervision using a 20 kHz pilot tone is supported, with detection on the audio input of the transmitter and regeneration on the audio output of the receiver.

A configurable audio delay can be used to artificially delay the playback of audio for loudspeaker alignment, e.g. in tunnels.

#### Audio Routing

Audio signals can be routed in uni-cast to up to 16 receivers, preconfigured or on activation of control inputs. Receivers are able to re-broadcast the incoming audio stream to other receivers. In case the interfaces are on the same LAN also broadcast is supported.

In PCM and G.711 (uLaw and aLaw) full duplex audio interfacing between two units is possible.

#### Control inputs and outputs

The unit has eight control inputs with configurable supervision on open and/or short-circuits. Eight control outputs have dry relay contacts. Control inputs can be routed to control outputs for remote actions or to pass on fault information between audio transmitter and receiver, in both directions. Control inputs can also be configured to change the audio routing.

An additional dry relay contact is provided for fault indication of the unit, including a high temperature fault situation.

#### Network Interfaces

The unit interfaces to 10 and 100 Mbit Ethernet networks and announces its IP-address that was given by a DHCP server. It can also search the network for a free IP-address or can be given a static IP-address. A second Ethernet connection is available to support network redundancy.

An RS 232 interface is build-in to communicate additional serial data over the IP network.

#### Power Supplies

Two power supply connections are provided as main input and backup input with supervision of both supplies.

#### Controls and Indicators (front)

- Reset button, recessed
- Two status indicator LEDs for network
- Eight status LEDs for control inputs

#### Interconnections (rear)

- Eight control inputs on Euro-connector
- Eight control outputs on Euro-connector
- Fault relay output on Euro-connector
- Two balanced audio inputs on Euro-connector (one line input, one line / microphone input)
- Two balanced audio outputs on Euro-connector
- Two Ethernet connections on RJ45
- RS 232 on Sub-D
- RS 485 on Euro-connector (future use)

## 128 | Digital PA and Emergency Sound | Praesideo System

- Main power supply on jack
- Backup power supply on Euro-connector

## 2

## Certifications and Approvals

Region	Certification
Europe	CE
Safety	acc. to IEC 60065-98
Immunity	acc. to EN 55103-2 / EN 50130-4 / EN 55024
Emissions	acc. to EN 55103-1 / EN 55022
Emergency	acc. to EN 60849

## Parts Included

Quantity	Component
1	PRS-1AIP1 IP Audio Interface
1	Power supply
1	Set of connectors

## Technical Specifications

## Electrical

External power supply 1	18 to 56 VDC
External power supply 2	18 to 56 VDC
Power consumption	8 W max

## Microphone input

Sensitivity	-48.5 to -26 dBV
Impedance	1360 ohm
Frequency response	100 Hz to 15 kHz
S/N	>60 dB
Supervision detection	Electret: 0.4 – 5 mA Dynamic: 120 – 1300 ohm

## Line Inputs

Sensitivity	-16.5 to +6 dBV
Impedance	22 kohm
Frequency response	20 Hz to 15 kHz
S/N	>70 dB
Pilot tone detection level (input 2 only)	-30 dBV

## Line outputs

Level	6 dBV max
Pilot tone level (output 2 only)	-20 dBV (20 kHz)

## Audio formats

MPEG 1-layer 3 (MP3)	32, 44.1 and 48 kHz sample rate Encoding up to 192 kbps VBR Decoding up to 320 kbps (stereo)
MPEG 1-layer 2	16, 22.05 and 24 kHz sample rate
G.711	uLaw, aLaw at 8, 24 or 32 kHz sample rate

PCM	16-bit at 8, 24 or 32 kHz sample rate
<b>Control inputs</b>	8 x
Connectors	Removable screw terminals
Operation	Closing contact (with supervision)
<b>Control / fault outputs</b>	8 x / 1 x
Connectors	Removable screw terminals
Operation	Make contact (SPST, voltage free)
Rating	24 V, 0.5 A
<b>Ethernet</b>	
Connector	Dual RJ45, DTE-pinout
Standard	802.3i / 802.3u
Speed	10 / 100 Mbps, auto-negotiation
Flow	Full / half-duplex, auto-negotiation
Protocol	TCP/IP, UDP, RTP, IGMP, DHCP, SNMP

## RS 232

Connector	9-pin Sub-D male, DTE-pinout
Pinout	300 to 115.200 Baud
Setting (default)	9600, 8, N, 1

## Mechanical

Dimensions (H x W x D)	216 x 38 x 125 mm (8.5 x 1.5 x 4.92 in) (half 19" wide)
Weight	0.7 kg (1.5 lb)
Mounting	Stand-alone or in 19"-rack with additional frame
Color	Silver with Charcoal

## Environmental

Operating temperature	-5 °C to +50 °C (+23 °F to +122 °F)
Start-up temperature	0 °C to +50 °C (+32 °F to +122 °F)
Storage temperature	-20 °C to +70 °C (-4 °F to +158 °F)
Humidity	15 to 90 %
Air pressure	600 to 1100 hPa

## Ordering Information

## PRS-1AIP1 IP Audio Interface

universal, IP-based audio device supporting VoIP and Audio over IP applications.

## PRS-1AIP1

## LBB 4402/00 Audio Expander



### Features

- ▶ **Four audio inputs – two selectable mic/line and two line inputs**
- ▶ **Four line audio outputs**
- ▶ **Eight supervised control inputs and five control outputs**
- ▶ **Audio processing functions**
- ▶ **Redundant network connection**
- ▶ **Headphone connection and VU meter for audio monitoring**

The audio expander inserts external audio into the system and extracts audio from the system. This unit has control inputs and outputs for external interfacing. It can route its audio inputs permanently or conditionally to any of the zones or to other audio outputs. The routing conditions are configured using the configuration software. The audio output can be programmed to get its signal from any of the audio inputs. The equipment can be used freestanding (tabletop) or in a 19" rack.

### Functions

The audio expander has four transformer isolated analog audio inputs. Two of these are selectable between microphone and line. The other two inputs are fixed line inputs. The expander has four transformer isolated analog audio line outputs. It has built-in digital audio processing capable of three parametric and two shelving equalizer sections for all audio in and outputs. They also have a selectable 20 kHz monitoring signal. The 2 x 16-character display and the rotary control enable local status enquiries.

The display shows the VU-meter reading when audio monitoring mode is active. Audio can also be monitored by using a headphone.

The eight control inputs are freely programmable for system actions, and priorities can be assigned to these inputs. Each control input has the ability to monitor the attached line for open and short-circuits. Five control outputs are freely programmable for faults and call-related actions.

The audio expander supports redundant network cabling. The network can be either single branch or redundant loop. The unit is powered from the network controller via the network cable. The expander is self-monitoring and continuously reports its status to the network controller.

### Controls and Indicators

- Two x 16-character LCD status display
- Rotary/push control for menu control and headphone volume

### Interconnections

- Two system network connections
- Eight control inputs
- Two mic/line inputs
- Two line inputs
- Four line outputs
- Five control outputs
- Headphone output

### Certifications and Approvals

Region	Certification
Europe	CE
Poland	CNBOP
Safety	acc. to IEC 60065 / EN 60065
Immunity	acc. to EN 55103-2
Emissions	acc. to EN 55103-1 / FCC-47 part 15B
Emergency	acc. to EN 60849 / EN 54-16 / ISO 7240-16
Maritime	acc. to IEC 60945

### Installation/Configuration Notes

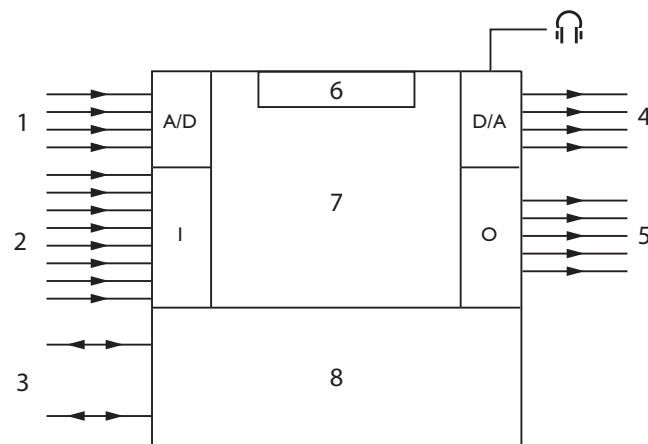

**130 | Digital PA and Emergency Sound | Praesideo System****2**

- 1 Audio inputs
- 2 Control inputs
- 3 Plastic optical fiber network
- 4 Audio outputs
- 5 Control outputs
- 6 Display and control
- 7 Network processor and DSP
- 8 Network redundancy switching

**Parts Included****Quantity Component**

1	LBB 4402/00 Audio Expander
1	Set of mounting brackets for 19" rack
1	Set of feet
1	Set of connectors

**Technical Specifications****Electrical**

Power consumption	9 W (DC)
-------------------	----------

**Performance**

Frequency response	20 Hz to 20 kHz (-3 dB)
--------------------	-------------------------

**Line inputs** 2 x

Connectors	3-pin XLR and 2 cinch (for each line)
------------	---------------------------------------

S/N	>87 dBA at maximum level
-----	--------------------------

CMRR	>40 dB
------	--------

Input range	+6 dBV to +18 dBV (XLR) -6 dBV to +6 dBV (cinch)
-------------	---

**Mic / line inputs** 2 x

Connector	3-pin XLR and 2 cinch (for each line)
-----------	---------------------------------------

Nominal Input Level	-57 dBV
---------------------	---------

S/N	>62 dBA with 25 dB headroom
-----	-----------------------------

CMRR	>55 dB at 100 Hz
------	------------------

Input Impedance	1360 ohm
-----------------	----------

Phantom supply	12 V ±1 V at 15 mA
----------------	--------------------

Input range	-7 dB to 8 dB ref nominal input level
-------------	---------------------------------------

**Line outputs** 4 x

Connectors	XLR and 2 cinch (for each line)
------------	---------------------------------

Output Impedance	<100 ohm
------------------	----------

S/N	>89 dBA at maximum level
-----	--------------------------

Crosstalk	<-85 dB
-----------	---------

Signal range	-12 dBV to +18 dBV (XLR) -24 dBV to +6 dBV (cinch)
--------------	---

Distortion at 1 kHz	<0.05%
---------------------	--------

**Control inputs** 8 x

Connectors	Removable screw terminals
------------	---------------------------

Operation	Closing contact (with supervision)
-----------	------------------------------------

**Control outputs** 5 x

Connectors	Removable screw terminals
------------	---------------------------

**Mechanical****Dimensions (H x W x D)**

for tabletop, with feet	92 x 440 x 400 mm (3.6 x 17.3 x 15.7 in)
-------------------------	---

for 19" rack, with brackets	88 x 483 x 400 mm (3.5 x 19 x 15.7 in)
-----------------------------	---

in front of brackets	40 mm (1.6 in)
----------------------	----------------

behind brackets	360 mm (14.2 in)
-----------------	------------------

Weight	7 kg (15.4 lbs)
--------	-----------------

Mounting	Tabletop, 19"-rack
----------	--------------------

Color	Charcoal (PH 10736) with silver
-------	---------------------------------

**Environmental**

Operating temperature	-5 °C to +55 °C (23 °F to 131 °F)
-----------------------	-----------------------------------

Storage temperature	-20 °C to +70 °C (-4 °F to 158 °F)
---------------------	------------------------------------

Humidity	15% to 90%
----------	------------

Air pressure	600 to 1100 hPa
--------------	-----------------

**Ordering Information****LBB 4402/00 Audio Expander****LBB4402/00**

Inserts external audio into the system and extracts audio from the system.

## LBB 4404/00 CobraNet Interface



### Features

- ▶ **Four CobraNet™ audio inputs**
- ▶ **Four CobraNet™ audio outputs**
- ▶ **Eight supervised control inputs and five control outputs**
- ▶ **Redundant Praesideo network connection**
- ▶ **Redundant CobraNet™ network connection**
- ▶ **Headphone connection and VU-meter for audio monitoring**

CobraNet™, developed by Peak Audio, is a network protocol for real-time uncompressed digital audio distribution over industry standard 100Base-T Ethernet networks. Typical applications are room coupling and audio distribution over long distances.

CobraNet™ audio channels can be configured as inputs to a Praesideo system, where they can be routed permanently or conditionally to any of the zones or audio outputs. The routing conditions are configured using the configuration software. Calls and background music (BGM) sources can be routed to CobraNet™ channels. Digital audio data is directly converted between an audio system and CobraNet™, with no other audio processing than sample rate conversion. Control inputs and outputs are provided for external interfacing. The equipment can be used free-standing (tabletop) or in a 19" rack.

CobraNet™ is a registered trademark of Peak Audio, a Division of Cirrus Logic, Inc.

### Functions

The Praesideo CobraNet™ Interface can simultaneously interface up to four digital audio channels from CobraNet™ into an audio system and up to four audio channels from an audio system into a CobraNet™ network. This includes converting between the 44.1 kHz sample rate used by Praesideo, and the 48 kHz sample rate that CobraNet™ uses, as well as conserving volume levels. It can also route audio channels between itself and other CobraNet™ Interfaces, in the same or in other audio system networks, or to third party CobraNet™ units. Only audio channels are routed via the interface, not control data. This means that if units are used to link multiple systems, a PC master must always access the network controllers through their open interfaces for control purposes.

The eight control inputs are freely programmable for system actions, and priorities can be assigned to these inputs. Five control outputs are freely programmable for faults and call-related actions. Control inputs can also be programmed for momentary or toggle operation using the configuration software. Each control input has the ability to monitor the attached line for open and short-circuits.

The 2 x 16-character display and the rotary control enable local status enquiries. The display shows the VU-meter reading when the audio monitoring mode is active. Audio can be monitored by headphone.

The interface supports redundant network cabling of both an audio system and CobraNet™ networks. It gets its power from the network controller via the network cable. The unit is self-monitoring and continually reports its status to the network controller.

### Controls and indicators

- 2 x 16 character LCD status display
- Rotary/push control for menu control and headphone volume

### Interconnections

- Two optical network connections
- Two RJ45 Ethernet connectors for the CobraNet™
- Eight control inputs to enable audio inputs and audio outputs
- Five control outputs to indicate channel engaged state
- One headphone output 3.5 mm (0.14 in) stereo



Rear view

**132 | Digital PA and Emergency Sound | Praesideo System**

2

**Certifications and Approvals**

Region	Certification
Europe	CE
Safety	acc. to IEC 60065 / EN 60065
Immunity	acc. to EN 55103-2 / EN 50130-4 / EN 50121-4
Emissions	acc. to EN 55103-1 / FCC-47 part 15B
Emergency	acc. to EN 60849
Maritime	acc. to IEC 60945

**Installation/Configuration Notes**

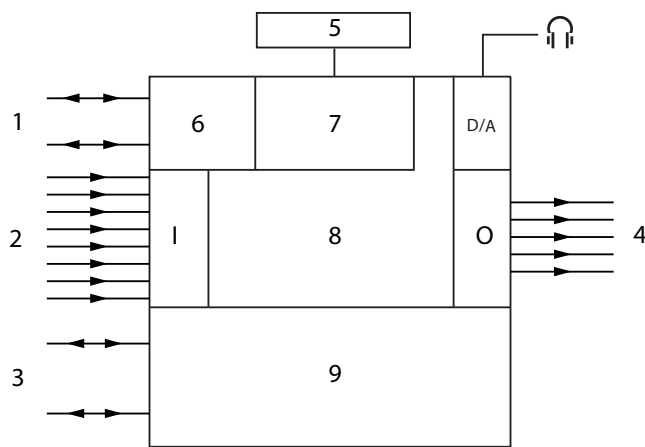

- 1 Ethernet network
- 2 Control inputs
- 3 Plastic optical fiber network
- 4 Control outputs
- 5 Display and control
- 6 CobraNet™ interface
- 7 Sample rate conversion
- 8 Network processor and DSP
- 9 Network redundancy switching

**Parts Included**

Quantity	Component
1	LBB 4404/00 CobraNet Interface
1	Set of mounting brackets for 19" rack
1	Set of feet
1	Set of connectors

**Technical Specifications**

**Electrical**

Supply voltage	24 to 48 VDC
Power consumption	11 W (DC)
Audio Transport	Ethernet
Channels	4 in / 4 out per interface Max 64 on CobraNet™
Compliance	IEEE 802.3
Audio Transport	16 / 20 / 24-bit
Sample Rate	48 kHz
Latency	5.33 ms
Integrity assurance	Watchdog

**Control inputs**

Control inputs	8 x
Connectors	Removable screw terminals
Operation	Closing contact (with supervision)

**Control outputs**

Control outputs	5 x
Connectors	Removable screw terminals

**Mechanical**

Dimensions (H x W x D)	
for tabletop, with feet	92 x 440 x 400 mm (3.6 x 17.3 x 15.7 in)
for 19" rack, with brackets	88 x 483 x 400 mm (3.5 x 19 x 15.7 in)
in front of brackets	40 mm (1.6 in)
behind brackets	360 mm (14.2 in)

Weight	6 kg (13.2 lbs)
Mounting	Tabletop, 19"-rack
Color	Charcoal (PH 10736) with silver

**Environmental**

Operating temperature	-5 °C to +55 °C (23 °F to +55 °F)
Storage temperature	-20 °C to +70 °C (-4 °F to +158 °F)
Humidity	15% to 90%
Air pressure	600 to 1100 hPa

**Ordering Information**

**LBB 4404/00 CobraNet Interface** **LBB4404/00**  
network protocol for real-time uncompressed digital audio distribution over industry standard 100Base-T Ethernet networks.

## PRS-NSP Network Splitter



### Features

- ▶ Two current-limited network tap-offs
- ▶ Supports redundant network connection on main loop
- ▶ Can feed power from an external supply to the network
- ▶ Indicators for power and fault status

The network splitter is used in a network to provide two branches from the main cable run. It can use an external DC power supply, or it can use the power supply from the network controller. The unit automatically switches to the local power supply unit when it is connected to it, reducing the power drain on the main network. The network splitter can also function as a repeater, effectively extending the length of the main network another 50 meters.

### Functions

The splitter inserts Praesideo units connected to a tap-off into the main network, however without the redundancy of the main loop. The maximum current supplied for each of the two tap-offs is separately selectable. External power from the local supply is used only for the tap-offs, and is not fed into the main system cable. The network splitter has two LEDs for diagnostic purposes.

### Controls and indicators

- Power status LED
- Fault status LED
- Jumpers to configure tap-offs power behavior

### Interconnections

- Two system network connections for main network
- Two system network connection for network tap-offs
- External power supply input

### Certifications and Approvals

Region	Certification
Europe	CE
Safety	acc. to IEC 60065 / EN 60065
Immunity	acc. to EN 55103-2 / EN 50130-4 / EN 50121-4
Emissions	acc. to EN 55103-1 / FCC-47 part 15B
Emergency	acc. to EN 60849 / EN 54-16 / ISO 7240-16
Maritime	acc. to IEC 60945

### Parts Included

Quantity	Component
1	PRS-NSP Network Splitter
1	Mounting bracket
1	Power supply connector

### Technical Specifications

#### Electrical

Power consumption	3.9 W (network)
-------------------	-----------------

#### External power supply

Voltage	24 to 56 VDC, 48 VDC nominal
Current	2.5 A maximum (5 A peak <2 s)

#### Mechanical

Dimensions (H x W x D)	
Without bracket	27 x 243 x 80 mm (1.1 x 9.6 x 3.1 in)
With bracket	34 x 243 x 84 mm (1.3 x 9.6 x 3.3 in)
Weight	0.7 kg (1.5 lb)
Mounting	Bracket (two screws)
Color	Charcoal

#### Environmental

Operating temperature	-5 °C to +55 °C (+23 °F to +131 °F)
Storage temperature	-20 °C to +70 °C (-4 °F to +158 °F)
Relative humidity	15% to 90%
Air pressure	600 to 1100 hPa

### Ordering Information

<b>PRS-NSP Network Splitter</b>	<b>PRS-NSP</b>
used in a network to provide two branches from the main cable run	

## PRS-FIN, PRS-FINNA and PRS-FINS Fiber Interfaces



### Features

- ▶ Redundant network connection
- ▶ Indicators for power and fault status
- ▶ Two supervised control inputs (not PRS-FINNA)
- ▶ Can use a local power supply

Most of the Praesideo system units have plastic fiber optic interfaces. Plastic fiber is used to interconnect nodes which are less than 50 meters apart. For distances of more than 50 meters, glass fiber optic cable is used. A fiber interface converts from plastic to glass fiber, and vice versa. The fiber interfaces have a power supply input to provide power to remote network sections, and two control inputs. The control inputs can pass on supervision information about the power supply connected to the fiber interface.

### Functions

These units interface glass fiber optical cable with plastic fiber optical cable, and support redundant wiring topology. In many applications this is necessary, because glass fiber can bridge much longer distances than plastic fiber. Any conversion to glass fiber must be converted back to plastic fiber before other Praesideo units can be attached, since they all have plastic fiber interfaces. This means that these units are always used in pairs.

Each interface can use an external 48 VDC power supply to provide power for itself, as well as for remote parts of the network. If there is no external power source, the interface uses power from the network controller. The PRS-FIN and PRS-FINS have two control inputs. These can be used to accept e.g. the fault output of the external

power supply (UPS), allowing the units to monitor the power supply and report faults to the network controller. The fiber interfaces have two LEDs for diagnostic purposes.

The PRS-FINNA is the same as the PRS-FIN except that it has no network node address. This has the advantage that the unit does not occupy one of the 60 possible addresses in the network. It also has the disadvantage that without an address, it is not possible to access the status of the two control inputs, as it is with the PRS-FIN.

The PRS-FINS is the same as the PRS-FIN, except that it accepts single-mode glass optical fiber instead of multi-mode glass optical fiber. However, this does not increase the maximum permitted cable length of a Praesideo network.

### Controls and indicators

- Power status LED
- Network status LED

### Interconnections

- Network connection for plastic optical fiber
- Network connection for glass optical fiber
- External power supply input
- Two control inputs (not PRS-FINNA)

### Certifications and Approvals

Safety	acc. to IEC 60065 / EN 60065
Immunity	acc. to EN 55103-2 / EN 50130-4 / EN 50121-4
Emissions	acc. to EN 55103-1 / FCC-47 part 15B
Emergency	acc. to EN 60849 / EN 54-16 / ISO 7240-16
Maritime	acc. to IEC 60945

### Installation/Configuration Notes

The PRS-FINNA and the PRS-FIN are often used in combination. The PRS-FINNA is placed in the local (POF) network, and connected to a (remote) PRS-FIN, which can then provide remote monitoring.

The PRS-FINS is mostly used in installations where single-mode (mono-mode) glass fiber is already present. Otherwise multi-mode glass fiber is a cheaper alternative.

### Parts Included

Quantity	Component
1	PRS-FIN Fiber Interface or PRS-FINNA Fiber Interface Non-Addressable or PRS-FINS Fiber Interface Single Mode
1	Mounting bracket
1	Control input connector
1	Power supply connector

## Technical Specifications

### Electrical

Power consumption 4.6 W (DC)

### External power supply

Voltage 24 to 56 VDC, 48 VDC nominal

Current 2.5 A maximum (5 A peak <2 s)

**Control inputs** 2 x

Connector Screw terminals

Operation Closing contact (with supervision)

### Glass optical fiber interface

Connector (PRS-FIN and PRS-FINNA) SC (Avago AFBR-5803Z transceiver)

Connector (PRS-FINS) SC (Avago AFCT-5805BZ transceiver)

Wavelength 1300 nm

Cable type (PRS-FIN and PRS-FINNA) 62.5/125  $\mu\text{m}$  or 50/125  $\mu\text{m}$  multi-mode

Cable type (PRS-FINS) 9/125  $\mu\text{m}$  single-mode

### Mechanical

Dimensions (H x W x D)

Without bracket 27 x 243 x 80 mm (1.1 x 9.6 x 3.1 in)

With bracket 34 x 243 x 84 mm (1.3 x 9.6 x 3.3 in)

Weight 0.7 kg (1.5 lb)

Mounting Bracket (2 screws)

Color Charcoal

### Environmental

Operating temperature -5 °C to +55 °C (+23 °F to +131 °F)

Storage temperature -20 °C to +70 °C (-4 °F to +158 °F)

Humidity 15% to 90%

Air pressure 600 to 1100 hPa

## Ordering Information

<b>PRS-FIN Fiber Interface</b> full network address, multi-mode	<b>PRS-FIN</b>
--	----------------

<b>PRS-FINNA Fiber Interface Non-Addressable</b> no network address, multi-mode	<b>PRS-FINNA</b>
--	------------------

<b>PRS-FINS Fiber Interface Single Mode</b> full network address, single-mode	<b>PRS-FINS</b>
--	-----------------

## LBB 4442/00 Line Supervision Set

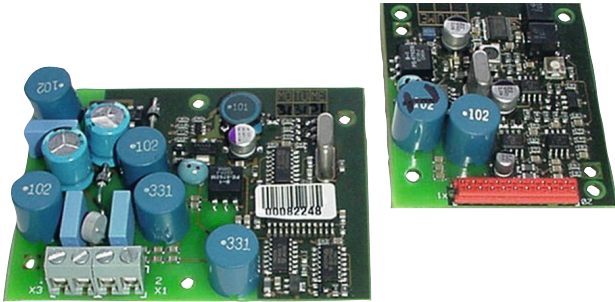

### Features

- ▶ Loudspeaker line monitoring without additional cabling
- ▶ Supervision-master mounting in the power amplifier
- ▶ Supervision-slave mounting at the end of the loudspeaker line
- ▶ Open-circuit fault detection
- ▶ Compatible with 100 V and 70 V loudspeaker lines
- ▶ Supervision-slave powered from the power amplifier

The Praesideo system uses a unique loudspeaker line monitoring principle, which requires no additional cable. The loudspeaker line itself is used to communicate with the supervision-slave installed at the end of the loudspeaker line.

The LBB 4442/00 contains the master and slave device for supervision of a single loudspeaker line. For supervision of multiple loudspeaker line branches and loudspeakers, the use of the LBB 4440/00 Supervision Control Board in conjunction with the LBB 4441/00 and LBB 4443/00 Supervision Boards is recommended.

### Functions

Each amplifier channel in an LBB 442x/x0 or PRS-xPxxx Power Amplifier unit has an internal mechanical and electrical provision for an LBB 4442/00 master board. The slave board fits into the Bosch range of loudspeakers and can be mounted in the last speaker in the line, or in a separate housing at the end of the line. The short-to-ground and short-circuit detection for the lines are incorporated in the power amplifier. Line faults are detected and reported within 100 s. The pilot tone generator for speaker monitoring is generated in the amplifier and powers the slave unit. Line monitoring can be switched on and off from the configuration software.

### Interconnections

- 20-pin flat cable connector (master)
- Two screw terminals (slave)

### Certifications and Approvals

Region	Certification
Europe	CE
Poland	CNBOP
Safety	acc. to IEC 60065 / EN 60065
Immunity	acc. to EN 55103-2 / EN 50130-4 / EN 50121-4
Emissions	acc. to EN 55103-1 / FCC-47 part 15B
Emergency	acc. to EN 60849 / EN 54-16 / ISO 7240-16
Maritime	acc. to IEC 60945

### Installation/Configuration Notes

The following loudspeakers have a provision for installing a supervision board:

Ceiling loudspeakers	Column loudspeakers	Sound projectors
LC1-WM06E	LBC 3210/00	LBC 3432/02
LC1-UM06E	LA1-UM20E-1	LS1-OC100E-1
LC1-UM12E	LA1-UM40E-1	
LC1-UM24E		<b>Horn loudspeakers</b>
LBC 3510/40	LBC 3403/16	
LBC 3520/40	LBC 3404/16	
LBC 3530/40	LBC 3405/16	
<b>Cabinet loudspeakers</b>	LBC 3406/16	
LBC 3011/41	LH1-10M10E	
LBC 3011/51	LBC 3482/00	
LB1-UM06E-1	LBC 3483/00	
LBC 3018/01	LBC 3484/00	
LB1-UM20E-D/L	LH1-UC30E	
LB1-UM50E-D/L		
LB3-PC250		
LB3-PC350		

### Technical Specifications

#### Mechanical

##### Slave

Dimensions (H x W x D)	16 x 80 x 60 mm (0.6 x 3.1 x 2.3 inch)
Weight	50 g (1.7 ounces)
Mounting	2 screws

##### Master

Dimensions (H x W x D)	17 x 60 x 50 mm (0.7 x 2.3 x 2 inch)
Weight	30 g (1.1 ounces)
Mounting	Internally in all Praesideo Power Amplifiers

**Environmental**

Operating temperature	-5 °C to +55 °C (+23 to 131 °F)
Storage temperature	-20 °C to +70 °C (-4 to 158 °F)
Humidity	15% to 90%
Air pressure	600 to 1100 hPa

2

**Ordering Information**

<b>LBB 4442/00 Line Supervision Set</b>	<b>LBB4442/00</b>
contains the master and slave device for supervision of a single loudspeaker line	

**Accessories**

<b>LBB 4446/00 Set of Supervision Board Brackets (10 pcs)</b>	<b>LBB4446/00</b>
intended for mounting supervision boards.	

## LBB 4440/00 Supervision Control Board

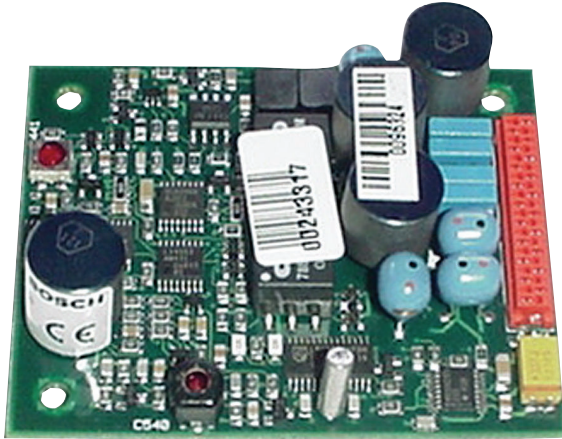

### Features

- ▶ **Multiple speaker and line monitoring without additional cabling**
- ▶ **Mounted inside the power amplifier**
- ▶ **Controls up to 80 speaker and line supervision boards**
- ▶ **Open-circuit fault detection**
- ▶ **Compatible with 100 V and 70 V loudspeaker lines**

The board controls the communication between the Praesideo system and the loudspeaker or loudspeaker line supervision boards.

The LBB 4440/00 is the supervision control board, monitoring multiple supervision-slave boards (LBB 4441/00 and LBB 4443/00), which are mounted inside the loudspeakers on the line. With these boards working together, it is possible to supervise 16, 64, or up to 80 loudspeakers or loudspeaker lines on a 500-watt amplifier.

### Functions

Each amplifier channel in an LBB 442x/10 Power Amplifier unit has an internal mechanical and electrical provision for an LBB 4440/00 control board. Communication between the supervision boards takes place inaudibly over the loudspeaker line, requiring no additional wiring. The audio signals on the lines do not affect communication.

Monitoring can be switched on and off from the configuration software. The monitoring of the presence of supervisor boards is continuous. Loudspeaker faults are detected and reported within 300 s, and line faults are detected and reported within 100 s.

### Interconnections

20-pin connector and flat cable

### Certifications and Approvals

Region	Certification	
Europe	CE	Declaration of Conformity
Poland	CNBOP	
Safety	acc. to IEC 60065 / EN 60065	
Immunity	acc. to EN 55103-2 / EN 50130-4 / EN 50121-4	
Emissions	acc. to EN 55103-1 / FCC-47 part 15B	
Emergency	acc. to EN 60849 / EN 54-16 / ISO 7240-16	
Maritime	acc. to IEC 60945	

### Installation/Configuration Notes

The following power amplifiers have a provision for installing a supervision control board:

- LBB 4421/10
- LBB 4422/10
- LBB 4424/10
- PRS-1P500
- PRS-2P250
- PRS-4P125

### Required loudspeaker line characteristics:

Preferred cable	Single twisted pair, 0.75 mm <sup>2</sup> to 1.5 mm <sup>2</sup>
Maximum length	1 km (including branches, max. 300 m adjacent to other supervised loudspeaker cables)
Maximum loop resistance	38 ohm
Maximum inductance	750 µH
Minimum total loudspeaker impedance	50 ohm @ 70 kHz (independent of amplifier power)
Maximum capacity	300 nF
Maximum number of supervision boards per amplifier channel	80 @ 500 W 40 @ 250 W 20 @ 125 W
Loudspeaker voltage	70 V, 100 V

**Note** The use of multi-wire cables is not recommended in combination with line supervision, because crosstalk between audio channels may influence the line supervision.

**Note** If the maximum load capacity for the power amplifier output is less than 300 nF, the maximum load capacity of the power amplifier is leading.

---

**Technical Specifications**
**Mechanical**

Dimensions (H x W x D)	60 x 50 x 17 mm without bracket (2.4 x 2.0 x 0.7 inch)
Weight	30 g (1 ounce)
Mounting	Internally in the power amplifier Plastic brackets for horizontal and vertical installation included

**Environmental**

Operating temperature	-5 °C to +55 °C (23 to 131 °F)
Storage temperature	-20 °C to +70 °C (-4 to 158 °F)
Humidity	15% to 90%
Air pressure	600 to 1100 hPa

---

**Ordering Information**

<b>LBB 4440/00 Supervision Control Board</b> for use in the power amplifier on each amplifier channel	<b>LBB4440/00</b>
--	-------------------

**Accessories**

<b>LBB 4441/00 Loudspeaker Supervision Board</b> monitors the integrity of a loudspeaker	<b>LBB4441/00</b>
<b>LBB 4443/00 End of Line (EOL) Supervision Board</b> monitors the integrity of a loudspeaker line	<b>LBB4443/00</b>

## LBB 4441/00 Loudspeaker Supervision Board

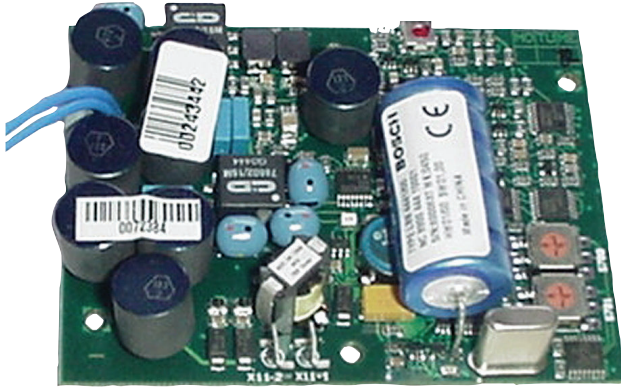

### Features

- ▶ Loudspeaker and loudspeaker line monitoring without additional cabling
- ▶ Open-circuit fault detection
- ▶ Compatible with 100 V and 70 V loudspeaker lines
- ▶ Powering of the supervision-board from the power amplifier
- ▶ Communication is not affected by the audio signals on the loudspeaker line

The board monitors the integrity of a loudspeaker. It works together with the LBB 4440/00 Supervision Control Board. The speaker status is communicated to the LBB 4440/00 via the existing loudspeaker cable.

### Functions

The LBB 4441/00 is mounted inside the loudspeaker casing and communicates the status of the loudspeaker to the LBB 4440/00 Supervision Control Board via the existing loudspeaker cable. The board detects and reports loudspeaker faults within 300 s, line faults within 100 s.

### Interconnections

- Two 30 cm flying leads
- Two faston connectors

### Certifications and Approvals

Region	Certification
Europe	CE

Safety	acc. to IEC 60065 / EN 60065
Immunity	acc. to EN 55103-2 / EN 50130-4 / EN 50121-4
Emissions	acc. to EN 55103-1 / FCC-47 part 15B
Emergency	acc. to EN 60849 / EN 54-16 / ISO 7240-16
Maritime	acc. to IEC 60945

### Installation/Configuration Notes

The following loudspeakers have a provision for installing a supervision board:

Ceiling loudspeakers	Column loudspeakers	Sound projectors
LC1-WM06E	LBC 3210/00	LBC 3432/02
LC1-UM06E	LA1-UM20E-1	LS1-OC100E-1
LC1-UM12E	LA1-UM40E-1	
LC1-UM24E		
	Horn loudspeakers	
LBC 3510/40	LBC 3403/16	
LBC 3520/40	LBC 3404/16	
LBC 3530/40	LBC 3405/16	
	Cabinet loudspeakers	
LBC 3011/41	LH1-10M10E	
LBC 3011/51	LBC 3482/00	
LB1-UM06E-1	LBC 3483/00	
LBC 3018/01	LBC 3484/00	
LB1-UM20E-D/L	LH1-UC30E	
LB1-UM50E-D/L		
LB3-PC250		
LB3-PC350		

The board must be connected after the ceramic terminal block with the thermal fuse. In case of a fire, the thermal fuse will blow and disconnect the board from the loudspeaker line. The trip point of the thermal fuse that is connected to the ceramic block is lower than the melting point of the solder on the board to prevent short-circuits in the supervision board and the loudspeaker line.

When the loudspeaker does not contain a ceramic terminal block with a thermal fuse, use an LBC 1256/00 EVAC Connection Adapter

### Technical Specifications

#### Mechanical

Dimensions (H x W x D)	78 x 60 x 22 mm (3.0 x 2.3 x 0.8 in)
Weight	70 g (2.4 ounces)
Mounting	Internally in the loudspeaker An optional mounting bracket, LBB 4446/00 is available

**Environmental**

Operating temperature	-5 °C to +55 °C (+23 °F to +131 °F)
Storage temperature	-20 °C to +70 °C (-4 °F to +158 °F)
Humidity	15% to 90%
Air pressure	600 to 1100 hPa

**Ordering Information**

<b>LBB 4441/00 Loudspeaker Supervision Board</b>	<b>LBB4441/00</b>
monitors the integrity of a loudspeaker	

**Accessories**

<b>LBB 4440/00 Supervision Control Board</b>	<b>LBB4440/00</b>
for use in the power amplifier on each amplifier channel	

<b>LBB 4446/00 Set of Supervision Board Brackets (10 pcs)</b>	<b>LBB4446/00</b>
intended for mounting supervision boards.	

<b>PRS-16MCI Multichannel Interface</b>	<b>PRS-16MCI</b>
a network interface to the Praesideo basic amplifiers.	

## LBB 4443/00 End of Line (EOL) Supervision Board

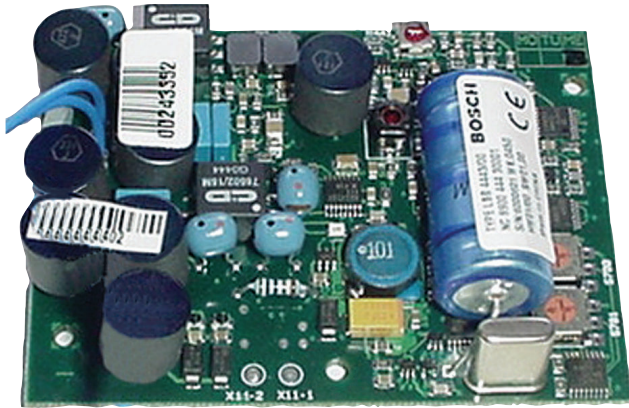

### Features

- ▶ Loudspeaker line monitoring without additional cabling
- ▶ Open-circuit fault detection
- ▶ Compatible with 100 V and 70 V loudspeaker lines
- ▶ Powering of the supervision-board from the power amplifier
- ▶ Communication is not affected by the audio signals on the line

The board monitors the integrity of a loudspeaker line. The boards work together with the LBB 4440/00 Supervision Control Board to monitor the status of the loudspeaker line and all of its branches. The line status is communicated to the LBB 4440/00 via the existing loudspeaker cable.

### Functions

The board is mounted inside the case of the last loudspeaker on the loudspeaker line, or inside a separate case. Supervision of branched lines is possible. If a loudspeaker line has multiple branches, a separate LBB 4443/00 is required for the last loudspeaker in each branch. The board detects and reports line faults within 100 s.

### Interconnections

- Two 30 cm flying leads
- Two faston connectors

### Certifications and Approvals

Region	Certification
Europe	CE
Poland	CNBOP
Safety	acc. to IEC 60065 / EN 60065
Immunity	acc. to EN 55103-2 / EN 50130-4 / EN 50121-4
Emissions	acc. to EN 55103-1 / FCC-47 part 15B
Emergency	acc. to EN 60849 / EN 54-16 / ISO 7240-16
Maritime	acc. to IEC 60945

### Installation/Configuration Notes

The following loudspeakers have a provision for installing a supervision board:

Ceiling loudspeakers	Column loudspeakers	Sound projectors
LC1-WM06E	LBC 3210/00	LBC 3432/02
LC1-UM06E	LA1-UM20E-1	LS1-OC100E-1
LC1-UM12E	LA1-UM40E-1	
LC1-UM24E	<b>Horn loudspeakers</b>	
LBC 3510/40	LBC 3403/16	
LBC 3520/40	LBC 3404/16	
LBC 3530/40	LBC 3405/16	
<b>Cabinet loudspeakers</b>	LBC 3406/16	
LBC 3011/41	LH1-10M10E	
LBC 3011/51	LBC 3482/00	
LB1-UM06E-1	LBC 3483/00	
LBC 3018/01	LBC 3484/00	
LB1-UM20E-D/L	LH1-UC30E	
LB1-UM50E-D/L		
LB3-PC250		
LB3-PC350		

### Technical Specifications

#### Mechanical

Dimensions (H x W x D)	78 x 60 x 22 mm (3.0 x 2.3 x 0.8 in)
Weight	70 g (2.4 ounces)
Mounting	Internally in the loudspeaker An optional mounting bracket, LBB 4446/00 is available

#### Environmental

Operating temperature	-5 °C to +55 °C (+23 °F to +131 °F)
Storage temperature	-20 °C to +70 °C (-4 °F to +158 °F)
Humidity	15% to 90%
Air pressure	600 to 1100 hPa

---

**Ordering Information**

<b>LBB 4443/00 End of Line (EOL) Supervision Board</b>	<b>LBB4443/00</b>
--	-------------------

monitors the integrity of a loudspeaker line

---

**Accessories**

<b>LBB 4440/00 Supervision Control Board</b>	<b>LBB4440/00</b>
--	-------------------

for use in the power amplifier on each amplifier channel

<b>LBB 4446/00 Set of Supervision Board Brackets (10 pcs)</b>	<b>LBB4446/00</b>
---	-------------------

intended for mounting supervision boards.

<b>PRS-16MCI Multichannel Interface</b>	<b>PRS-16MCI</b>
---	------------------

a network interface to the Praesideo basic amplifiers.

## LBB 4416/xx Network Cables



The network cables come in different lengths with connectors at both ends. The extension of the type number indicates the length of the cable. The LBB 4416/00 comes without connectors. The connectors (LBB 4417/00) are available for it separately.

### Functions

#### LBB 4416 /01 /02 /05 /10 /20 /50

These are special cables with two plastic fibers for data communication and two copper cores for the power supply.

The cables all have the network connectors fitted. They connect the network controller to power amplifiers, audio expanders, call stations etc.

#### LBB 4416/00

This is a special cable with two plastic fibers for data communication and two copper cores for the power supply.

The cable is 100 meters long, and comes without network connectors. LBB 4417/00 connectors are fitted after the cable has been cut to the required length. It connects the network controller to power amplifiers, audio expanders, call stations etc.

### Certifications and Approvals

Safety	acc. to IEC 60065 / EN 60065
Immunity	acc. to EN 55103-2 / EN 50130-4 / EN 50121-4
Emissions	acc. to EN 55103-1 / FCC-47 part 15B
Emergency	acc. to EN 60849 / EN 54-16 / ISO 7240-16
Maritime	acc. to IEC 60945

Flame retardant	acc. to IEC 60332-1 60s
Halogen level	acc. to IEC 60754-2 pH >4.3, conductivity <10 uS/mm
Smoke level	acc. to IEC 61034-2 light transmission >60%

### Installation/Configuration Notes

The cables have the following lengths

LBB4416/00	100 m (without connectors)
LBB4416/01	0.5 m
LBB4416/02	2 m
LBB4416/05	5 m
LBB4416/10	10 m
LBB4416/20	20 m
LBB4416/50	50 m

### Technical Specifications

#### Electrical

Wire	Copper, stranded 1 mm <sup>2</sup>
Resistance	<0.018 ohm/m

#### Optical

Fiber	PMMA, 1 mm
Numeric aperture	0.5
Attenuation	<0.17 dB/m @ 650 nm
Bending loss	<0.5 dB (r=20 mm, 90°) JIS C6861

#### Mechanical

Dimensions (diameter)	7 mm (0.28 in)
Color	Black
Pull force	150 N (max)

#### Environmental

Operating temperature	-40 °C to +65 °C (-40 °F to 149 °F)
Humidity	15% to 90%
Air pressure	600 to 1100 hPa

### Ordering Information

**LBB 4416/00 Network Cable 100m** **LBB4416/00**  
without the network connectors fitted

**LBB 4417/00 Set Network Connectors** **LBB4417/00**  
(20 pcs)  
20 connectors that can be used with the network cable.

**LBB 4418/00 Cable Connector Tool Kit** **LBB4418/00**  
Optical fiber cable connector tools

**LBB 4416/01 Network Cable Assembly** **LBB4416/01**  
**0.5m**  
with the network connectors fitted

---

**Ordering Information**

<b>LBB 4416/02 Network Cable Assembly 2m</b> with the network connectors fitted	<b>LBB4416/02</b>
<b>LBB 4416/05 Network Cable Assembly 5m</b> with the network connectors fitted	<b>LBB4416/05</b>
<b>LBB 4416/10 Network Cable Assembly 10m</b> with the network connectors fitted	<b>LBB4416/10</b>
<b>LBB 4416/20 Network Cable Assembly 20m</b> with the network connectors fitted	<b>LBB4416/20</b>
<b>LBB 4416/50 Network Cable Assembly 50m</b> with the network connectors fitted	<b>LBB4416/50</b>

---

**Accessories**

<b>LBB 4419/00 Cable Couplers (10 pcs)</b> used to couple LBB 4416/xx network cable assemblies for extension.	<b>LBB4419/00</b>
--	-------------------

## PLN-24CH12 24 V and PRS-48CH12 48 V Battery Chargers



### Features

- ▶ **12 A battery charger**
- ▶ **6x 40 A, 3x 5 A outputs**
- ▶ **150 A back-up current**
- ▶ **Fully supervised, EN 54-4 certified**
- ▶ **Under-voltage and over-voltage protection**

The PLN-24CH12 and PRS-48CH12 Battery Chargers are designed for public address and emergency sound systems, to assure that the system batteries are always charged. Rack mountable, the unit charges lead-acid batteries and simultaneously provides 24 V or 48 V for system components that use 24 V or 48 V exclusively. These chargers are fully compliant and certified to EN 54-4. The battery chargers are premium quality, intelligent, microprocessor controlled devices.

### Functions

#### Performance

The maximum charger current is 12 A for charging the battery. The maximum battery capacity, according to EN 54-4, is therefore 225 Ah, minimum size is 86 Ah. The maximum output of the back-up power system is 150 A.

The charger has an input voltage range of 195 V to 264 V, and a power factor corrector. The charger features automatic shutoff when the battery voltage is too low, to prevent battery damage. It also features over-voltage protection, protection against wrong battery polarity and short-circuit protection. The outputs are protected by fuses. The power supply takes a resistance measurement of the battery including connections every 4 hours.

The charger comes with a temperature sensor that is used to adjust the charging voltages.

The charger has additional 24 V or 48 V (depending on model) auxiliary outputs, to supply power to equipment that needs 24 V or 48 V as primary power. The current capacity of these outputs is 5 A per output.

The charger has relay outputs to signal a mains fault, battery fault and charger output voltage fault.

#### Controls and indicators

- Mains status LED
- Battery status LED
- Output voltage fault LED

#### Interconnections



- 6 main outputs for the system, each with their own fuse
- 3 auxiliary outputs for peripherals, system components that always use 24/48 V with a lower current need
- Fault relays
- Battery connection

### Certifications and Approvals

Safety	acc. to EN 60950-1
EMC	EN 61000-6-1 EN 61000-6-2 EN 61000-6-3 EN 61000-6-4 EN 55022 class B
Evacuation	acc. to EN 54-4 EN 12101-10 class A, part 10: power supplies. CE CPD: PLN-24CH12: 0333-CPD-075381-1 PRS-48CH12: 0333-CPD-075383-1
Immunity	acc. to EN 55130-1/2
Emission	acc. to EN 55103-4

### Installation/Configuration Notes

- 6 main outputs, 40 A (32 A GG fuse) per output.
- 3 auxiliary outputs, 5 A (5 AT fuse) per output.
- The maximum total back-up current is 150 A (9 outputs).
- The maximum charger output current to the battery and outputs combined is 12 A.

**Parts Included**

Quantity	Component
1	PLN-24CH12 24 V Battery Charger or PRS-48CH12 48 V Battery Charger
1	Mains plug
1	Installation and User Instructions
1	Temperature sensor with cable

**Technical Specifications****Electrical****Mains power supply**

Voltage	195 to 264 VAC, 50 to 60Hz
Input current (PLN-24CH12)	2 A
Input current (PRS-48CH12)	4 A
Power consumption (PLN-24CH12)	380 W maximum
Power consumption (PRS-48CH12)	760 W maximum

**Performance  
(PLN-24CH12)**

Voltage min.	21.6 VDC (auto shutdown)
Voltage max.	28.5 VDC

**Performance  
(PRS-48CH12)**

Voltage min.	43.2 VDC (auto shutdown)
Voltage max.	56.9 VDC

**Performance  
(PLN-24CH12 and  
PRS-48CH12)**

Max. charge current	12 A
Max. system current (lb)	150 A

**Main outputs (6 x)**

Voltage	24 or 48 VDC (battery voltage)
Current	40 A

**Auxiliary outputs (3 x)**

Voltage	24 or 48 VDC (battery voltage)
Current	5 A

**Fault outputs (3 x)**

Rating	24 V/1 A, 120VAC/500 mA voltage free
Contacts	Normally energized (failsafe)

**Mechanical**

Dimensions (H x W x D)	88 x 430 x 260 mm (19" wide, 2U high)
Input connections (connect to battery)	Screw terminal
Output connections (connect to system)	10 x pluggable screw connector
Weight	Approx. 6 kg
Mounting	19" rack
Color	Charcoal with silver

**Environmental**

Operating temperature	-5 °C to +45 °C (23 °F to +113 °F)
Storage temperature	-25 °C to +85 °C (-13 °F to +185 °F)
Relative humidity	<95% (operating and storage)

**Ordering Information**

<b>PLN-24CH12 24 V Battery Charger</b> Charges lead-acid batteries and simultaneously provides 24 V.	<b>PLN-24CH12</b>
<b>PRS-48CH12 48 V Battery Charger</b> Charges lead-acid batteries and simultaneously provides 48 V.	<b>PRS-48CH12</b>

## LBB 4417/00 Set Network Connectors (20 pcs)



The set contains 20 connectors that can be used with the network cable LBB 4416/00 to make up to ten custom cables. The cable/connector toolkit LBB 4418/00 is required for assembly.

### Certifications and Approvals

Region	Certification
Poland	CNBOP
Safety	acc. to IEC 60065 / EN 60065
Immunity	acc. to EN 55103-2 / EN 50130-4 / EN 50121-4
Emissions	acc. to EN 55103-1 / FCC-47 part 15B
Emergency	acc. to EN 60849 / EN 54-16 / ISO 7240-16
Maritime	acc. to IEC 60945

### Ordering Information

<b>LBB 4417/00 Set Network Connectors (20 pcs)</b>	<b>LBB4417/00</b>
20 connectors that can be used with the network cable.	

### Accessories

<b>LBB 4416/00 Network Cable 100m</b> without the network connectors fitted	<b>LBB4416/00</b>
--	-------------------

## LBB 4418/00 Cable Connector Tool Kit



### Parts Included

Quantity	Component
1	Standard cutting pliers
1	Stripping pliers
1	Crimping pliers
1	Plastic optical fiber cutting/stripping tool
1	Plastic optical fiber positioning and indent tool
1	Torx screw driver
1	Spare cutting system

### Ordering Information

<b>LBB 4418/00 Cable Connector Tool Kit</b>	<b>LBB4418/00</b>
Optical fiber cable connector tools	

### Accessories

<b>LBB 4418/50 Spare Cutting System (2 pcs)</b>	<b>LBB4418/50</b>
two replacement cutting systems for LBB 4418/00	

## LBB 4418/50 Spare Cutting System (2 pcs)



This set contains two replacements for the plastic optical fiber cutting/stripping tool contained in LBB 4418/00.

### Installation/Configuration Notes

After 1260 cuts, the cutter/stripping tool in the LBB 4418/00 blocks automatically. In that case, the cutting system must be replaced.

### Ordering Information

<b>LBB 4418/50 Spare Cutting System (2 pcs)</b>	<b>LBB4418/50</b>
two replacement cutting systems for LBB 4418/00	

## LBB 4419/00 Cable Couplers (10 pcs)

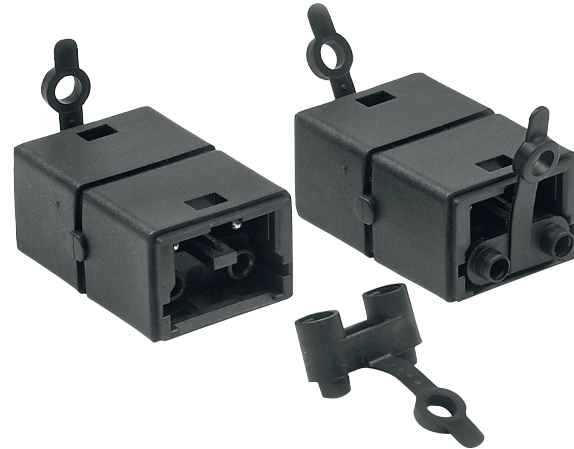

Cable couplers are used to couple LBB 4416/xx network cable assemblies for extension.

### Certifications and Approvals

Safety	acc. to IEC 60065 / EN 60065
Immunity	acc. to EN 55103-2 / EN 50130-4 / EN 50121-4
Emissions	acc. to EN 55103-1 / FCC-47 part 15B
Emergency	acc. to EN 60849 / EN 54-16 / ISO 7240-16
Maritime	acc. to IEC 60945

### Ordering Information

<b>LBB 4419/00 Cable Couplers (10 pcs)</b>	<b>LBB4419/00</b>
used to couple LBB 4416/xx network cable assemblies for extension.	

## LBB 4436/00 Set of Key Covers (10 pcs)

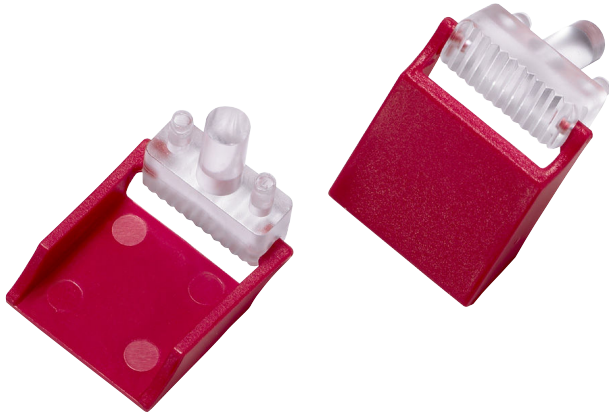

The key covers are snap-on replacements for the original lenses on an LBB 4432/00 Call Station Keypad that protect the keys from being accidentally pressed.

### Parts Included

Quantity	Component
10	Key covers
10	Replacement lenses

### Ordering Information

<b>LBB 4436/00 Set of Key Covers (10 pcs)</b>	<b>LBB4436/00</b>
10 key covers and 10 replacement lenses	

### Accessories

<b>LBB 4432/00 Call Station Keypad</b>	<b>LBB4432/00</b>
has eight programmable buttons, each with a two-color status LED.	

## LBB 4446/00 Set of Supervision Board Brackets (10 pcs)

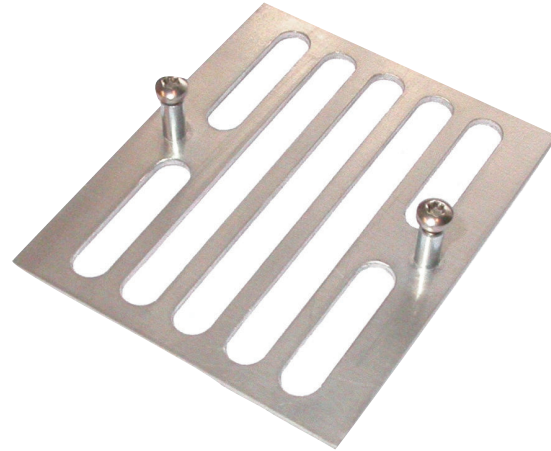

The supervision board brackets are intended for mounting LBB 4442/00 Supervision Slave Boards, LBB 4441/00 Loudspeaker Supervision Boards and LBB 4443/00 EOL Supervision Boards into or onto loudspeaker cabinets, or into junction boxes and equipment racks.

### Parts Included

Quantity	Component
10	Supervision Board Brackets

### Ordering Information

<b>LBB 4446/00 Set of Supervision Board Brackets (10 pcs)</b>	<b>LBB4446/00</b>
intended for mounting supervision boards.	

### Accessories

<b>LBB 4441/00 Loudspeaker Supervision Board</b>	<b>LBB4441/00</b>
monitors the integrity of a loudspeaker	
<b>LBB 4442/00 Line Supervision Set</b>	<b>LBB4442/00</b>
contains the master and slave device for supervision of a single loudspeaker line	
<b>LBB 4443/00 End of Line (EOL) Supervision Board</b>	<b>LBB4443/00</b>
monitors the integrity of a loudspeaker line	